

# Underground **INSTALLATION**

**TAMBE** METAL PRODUCTS

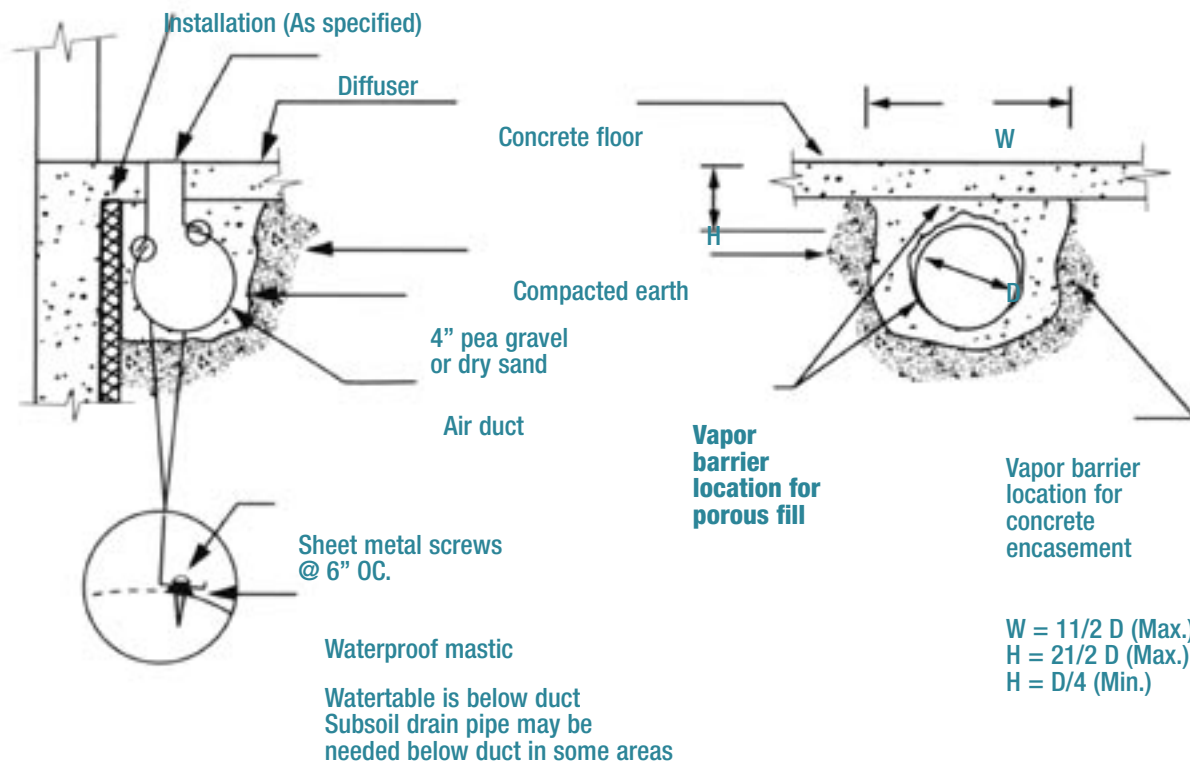
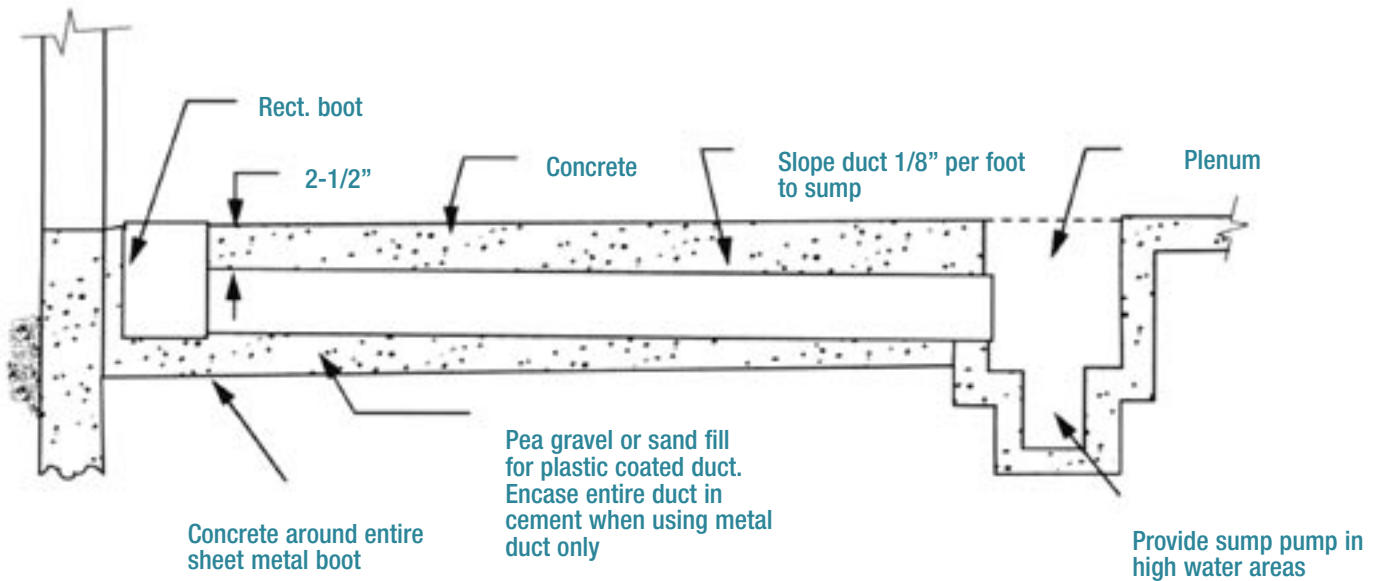

# Underground **INSTALLATION**

**TAMBE** METAL PRODUCTS

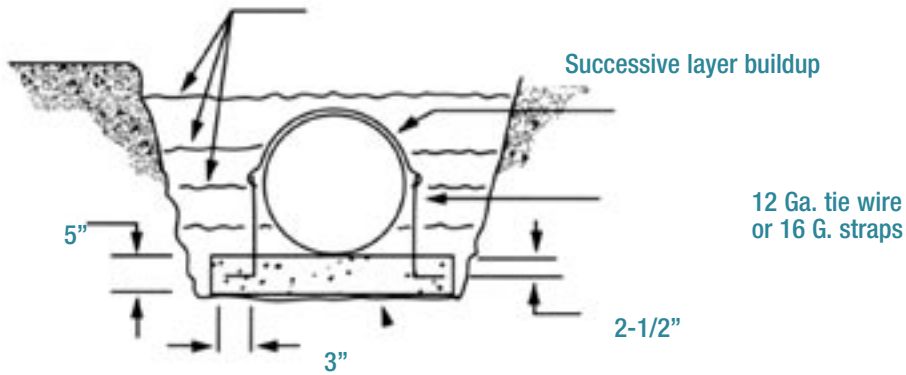

**Pre-poured base slab**

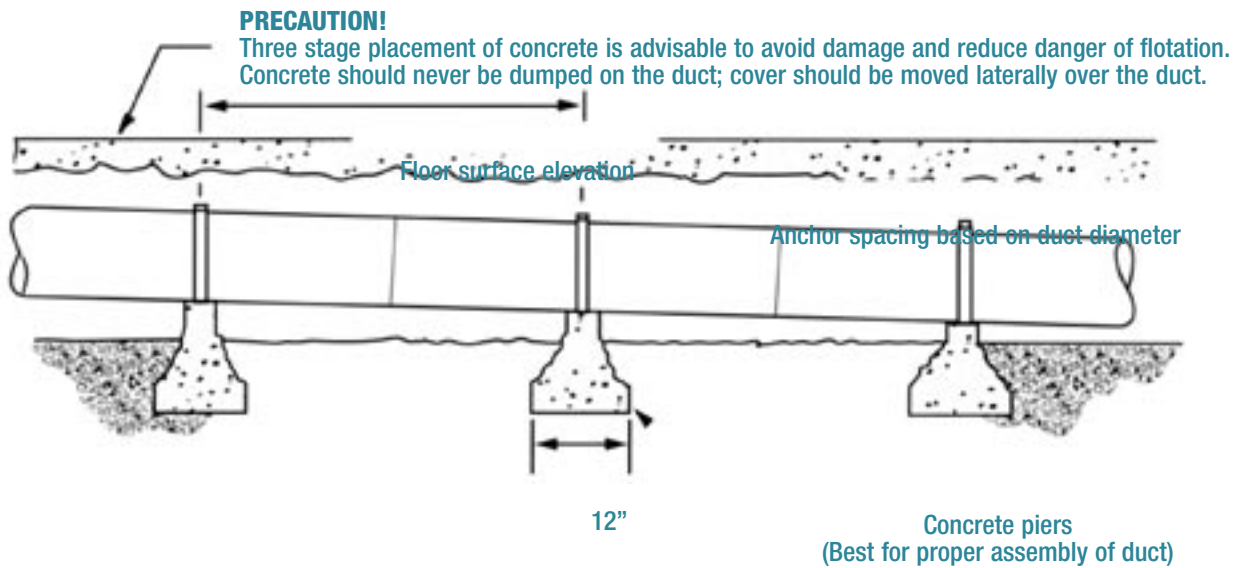

**Typical anchorage of ducts to be encased in concrete**

\* This illustration is a design guide