

SPIRAL ROUND DUCT SYSTEMS

TAMBE METAL PRODUCTS

Energy Efficient

Cost less to install

Often requires less space

Needs less hangers

Operation costs lower

More noise free

Installation simplified

Cleaning less complicated

Airflow measurements easier

Lighter in weight



Round Duct CONSTRUCTION STANDARDS

TAMBE METAL PRODUCTS

MAX DIAMETER	POSITIVE PRESSURE					
	+2" w.g.		+4" w.g.		+10" w.g.	
	Spiral Seam	Long. Seam	Spiral Seam	Long. Seam	Spiral Seam	Long. Seam
6"	28	28	28	28	28	28
8"	28	28	28	28	28	26
10"	28	26	28	26	28	26
12"	28	26	28	26	26	24
14"	28	26	26	24	26	24
16"	26	24	26	24	24	22
18"	26	24	24	24	24	22
19-26"	26	24	24	22	24	22
27-36"	24	22	22	20	22	20
37-50"	22	20	20	20	20	20
51-60"	20	18	18	18	18	18
61-84"	18	16	18	16	18	16

MAX DIAMETER	NEGATIVE PRESSURE					
	-2" w.g.		-4" w.g.		-10" w.g.	
	Spiral Seam	Long. Seam	Spiral Seam	Long. Seam	Spiral Seam	Long. Seam
6"	28	28	28	28	26	26
7"	28	28	28	28	26	26
8"	28	28	28	28	26	26
9"	28	28	28	26	26	24
10"	28	28	26	26	26	22
11"	28	26	26	24	26	22
12"	28	26	26	24	24	22
13"	28	26	26	24	24	20
14"	28	24	24	22	24	20
15"	28	24	24	22	22	20
16"	26	24	24	22	22	18
17"	26	24	24	20	22	18
18"	24	22	24	20	22	18
19"	24	22	24	20	22	18
20"	24	22	22	20	22	18
21"	24	20	22	18	22	18
22"	24	20	22	18	22	16
23"	24	20	22	18	20	16
24"	22	20	22	18	20	16
25-26"	22	20	20	18	20	18 A4
27-29"	22	18	20	16	18	16 A4
30"	22	18	20	16	18	16 B4
31-33"	20	18	20	16	18	16 B4
34"	20	18	20	20 A6	18	16 B4
35-36"	20	16	20	20 A6	18	16 B4
37-42"	20	16	18	18 B6	18 F12	
43-48"	20	18 A6	18	18 B6	18 F6	
49-60"	18	18 B4	18 F6	16 B4	18 F6	
61-72"	16		18 F6		16 F4	

An alphabet letter in the table means that reinforcement angles or their equivalent must be used at the foot interval following the letter. The angle sizes are:

A = 1" x 1" x 1/8"; **B** = 1-1/4" x 1-1/4" x 3/16"; **C** = 1-1/2" x 1-1/2" x 3/16"; **D** = 1-1/2" x 1-1/2" x 1/4"; **E** = 2" x 2" x 3/16"; **F** = 2" x 2" x 1/4"

If companion flange joints are used as reinforcements, those for 25" to 36" diameter shall be 1-1/2" x 1-1/2" x 3/16"; for 37" to 48" diameter 2" x 2" x 3/16"; for 40" to 60" diameter 2-1/2" x 2-1/2" x 3/16"; for 61" to 72" diameter 3" x 3" x 1/4".

Round Duct **CONSTRUCTION STANDARDS**

TAMBE METAL PRODUCTS

ALUMINUM ROUND DUCT GAUGE SCHEDULE

Duct Diameter in inches	Maximum +2" w.g. Static Positive		Maximum -2" w.g. Static Negative	
	Spiral Gauge Seam	Longitudinal Gauge Seam	Spiral Gauge Seam	Longitudinal Gauge Seam
3 thru 8"	.025"	.032"	.025"	.040"
9 thru 14"	.025"	.032"	.032"	.040"
15 thru 26"	.032"	.040"	.040"	.050"
27 thru 36"	.040"	.050"	.050"	.063"
37 thru 50"	.050"	.063"	.063"	.071"
51 thru 60"	.063"	.071"	N.A.	.090"
61 thru 84"	N.A.	.090"	N.A.	N.A.

POLYVINYL COATED DUCT GAUGES FOR UNDERGROUND DUCT AND FITTINGS

Duct Diameter in inches	Gauges	Fittings
4 thru 8"	26 Gauge	26 Gauge
9 thru 16"	24 Gauge	24 Gauge
18 thru 24"	22 Gauge	22 Gauge
26 thru 32"	20 Gauge	20 Gauge
34 thru 60"	18 Gauge	18 Gauge

POLYVINYL COATED DUCT GAUGES FOR ABOVE GROUND DUCT AND FITTINGS

Duct Diameter in inches	Gauges	Fittings
4 thru 14"	26 Gauge	26 Gauge
16 thru 26"	24 Gauge	24 Gauge
28 thru 36"	22 Gauge	22 Gauge
38 thru 50"	20 Gauge	20 Gauge
52 thru 60"	18 Gauge	18 Gauge

* Gauges equal or exceed SMACNA standards

Round Duct **SEAMS**

TAMBE METAL PRODUCTS



Spiral pipe lock seam (RL-1)

**Available
Gauges**

Galvanized	28-16
Stainless steel	26-22
Aluminum	22-16
Paint grip	26-16
Poly vinyl coated	26-18
Perforated	22



Spiral pipe lock seam (RL-1)
(Corrugated 14" and larger for extra strength below grade)

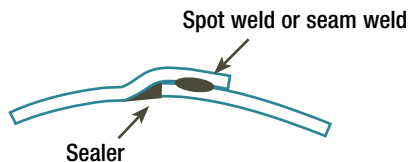

Spot weld and bonded seam
or continuous seam weld

Galvanized	26-20
Stainless steel	26-20
Aluminum	22-20
Paint grip	26-20
Poly vinyl coated (button punched or riveted)	26-18



Butt-welded seam

Galvanized	20-10
Stainless steel	20-10
Aluminum	18-1/4"
Paint grip	20-10

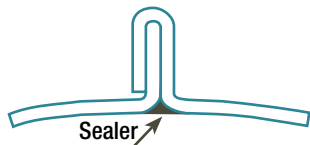

Gore locked seam

Galvanized	26-18
Stainless steel	26-22
Aluminum	22-16
Paint grip	26-18
Poly vinyl coated	26-18

Round Duct CONNECTORS

TAMBE METAL PRODUCTS

Angle Iron Ring Specifications

ORDER SIZE	ANGLE MILD STEEL	I.D.	BOLT HOLES	HOLE SIZE	BOLT CIRCLE	WEIGHT LBS.
3	PRESSED	3-1/16	6	9/32	4-5/16	0.70
4	10 GA	4-1/16	6	9/32	5-5/16	0.85
5		5-1/16	6	9/32	6-5/16	1.20
6	1-1/4 X	6-1/8	6	3/8	7-5/16	1.75
7	1-1/4 X	7-1/8	6	3/8	8-1/2	2.00
8	1/8	8-1/8	6	3/8	9-9/16	2.25
9		9-1/8	6	3/8	10-5/8	2.50
10		10-1/8	6	3/8	11-13/16	2.75
11		11-1/8	6	3/8	12-3/4	3.00
12	1-1/2 X	12-3/16	8	7/16	14	4.00
13	1-1/2 X	13-3/16	8	7/16	15	4.25
14	1/8	14-3/16	8	7/16	16	4.75
15		15-3/16	8	7/16	17	5.00
16	1-1/2 X	16-3/16	8	7/16	18	8.00
17	1-1/2 X	17-	8	7/16	19	8.25
18	3/16	3/1618-	8	7/16	20	8.50
19		3/16	12	7/16	20 3/4	8.75
20		19-3/16	12	7/16	21-3/4	9.50
21		20-3/16	12	7/16	22-3/4	10.25
22		21-3/16	12	7/16	23-3/4	10.75
23		22-3/16	12	7/16	24-7/8	11.25
24		23-3/16	12	7/16	25-7/8	11.50
25	2X2 X	24-3/16	16	7/16	26-7/8	15.75
26	3/16	25-3/16	16	7/16	28-3/8	16.50
27		26-	16	7/16	29-3/8	16.75
28		3/1627-	16	7/16	30-3/8	18.00
29		3/16	16	7/16	31-3/8	18.75
30		28-3/16	16	7/16	32-3/8	19.50
31		29-3/16	16	7/16	33-3/8	19.75
32		30-3/16	16	7/16	34-3/8	20.00
33		31-3/16	16	7/16	35-3/8	21.25
34		32-3/16	16	7/16	36-3/8	22.50
35		33-3/16	16	7/16	37-3/8	22.75
36		34-3/16	16	7/16	38-3/8	23.00
37		35-	24	7/16	39-3/8	23.75
38		3/1636-	24	7/16	40-3/8	24.50
39		3/16	24	7/16	41-3/8	25.00
40		37-3/16	24	7/16	42-3/8	25.75
41		38-3/16	24	7/16	43-3/8	26.25
42		39-3/16	24	7/16	44-3/8	26.50
43		40-3/16	24	7/16	45-3/8	27.50
44		41-3/16	24	7/16	46-3/8	28.00
45		42-3/16	24	7/16	47-3/8	28.50
46		43-3/16	24	7/16	48-3/8	29.00
47		44-3/16	24	7/16	49-3/8	30.00
48		45-3/16	24	7/16	50-3/8	30.75
49		46-3/16	24	7/16	51-3/8	31.50
50		47-3/16	24	7/16	52-3/8	32.00
52		48-3/16	24	7/16	54-3/8	33.75
54		49-3/16	24	7/16	56-3/8	35.00
56		50-3/16	24	7/16	58-3/8	36.25
58		52-3/16	24	7/16	60-3/8	37.50
60		54-3/16	24	7/16	62-3/8	38.75
62		56-3/16	24	7/16	64-3/8	40.00
64		58-3/16	24	7/16	66-3/8	41.50
66		60-3/16	24	7/16	68-3/8	42.75
68		62-3/16	24	7/16	70-3/8	44.00
70		64-3/16	24	7/16	72-3/8	45.25
72		66-3/16	24	7/16	74-3/8	46.50

Vanstone Flange/Companion Flange

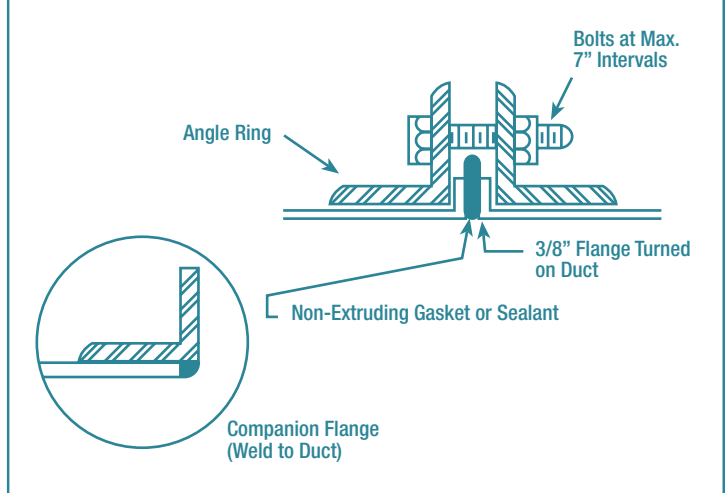

Oval Angle Ring Dimensions

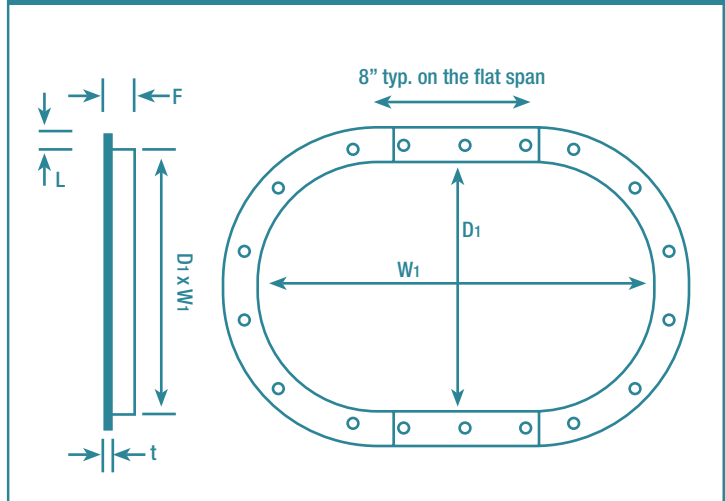

a Minor Axis (inches)	Bolt Hole Diameter (inches)	Number of Bolts on Curved Side	LxF Nominal Size (inches)	t Nominal Thickness
3-5	9/32	6	1 x 1	10 gauge
5-11	3/8	6	1-1/4 x 1-1/4	1/8"
12-14	7/16	8	1-1/2 x 1-1/2	1/8"
16-18	7/16	8	1-1/2 x 1-1/2	3/16"
19-24	7/16	12	1-1/2 x 1-1/2	3/16"
25-36	7/16	16	2 x 2	3/16"
37-50	7/16	24	2 x 2	3/16"

Standard Rings are hot rolled steel.
Galvanized, aluminum, and stainless steel rings are also available.

Round Duct **INSTALLATION**

TAMBE METAL PRODUCTS

Installation of slip joint connectors

Duct-to-joint connections are made by using a duct coupling that slips inside the duct sections.

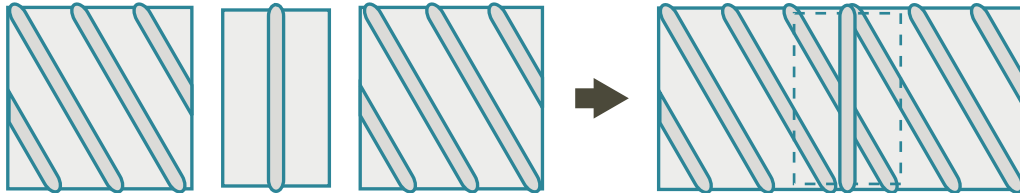

Duct-to-fitting connections

Duct-to-fitting connections are made by slipping the fitting collar into the duct.

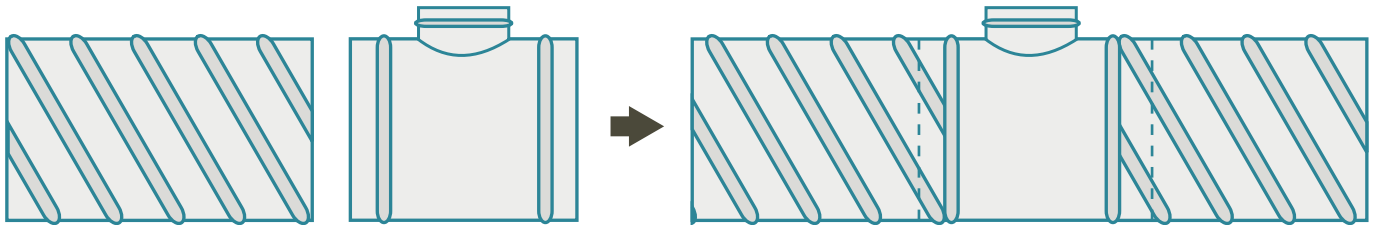

Fitting-to-fitting connections

Connections can be made by using a short section of duct or by using a fitting coupling.

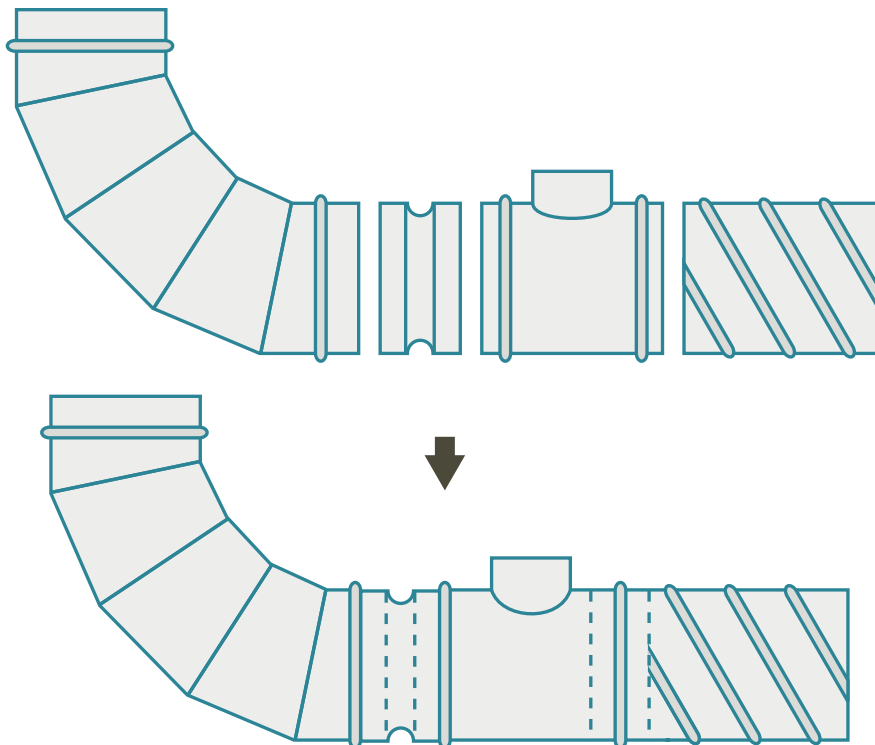

Round Duct **MANIFOLDS/ASSEMBLIES**

TAMBE METAL PRODUCTS

Tambe Metal Products standard manifolds/assemblies of duct and fittings

We offer manifolds/assemblies of duct and fittings from our standard duct and fitting components. Manifolds/assemblies reduce field labor and potential sources of leakage by eliminating joints between pipe and standard fittings.

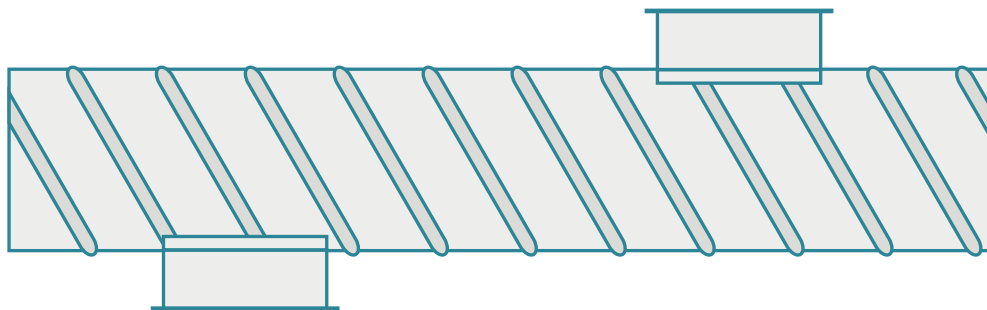
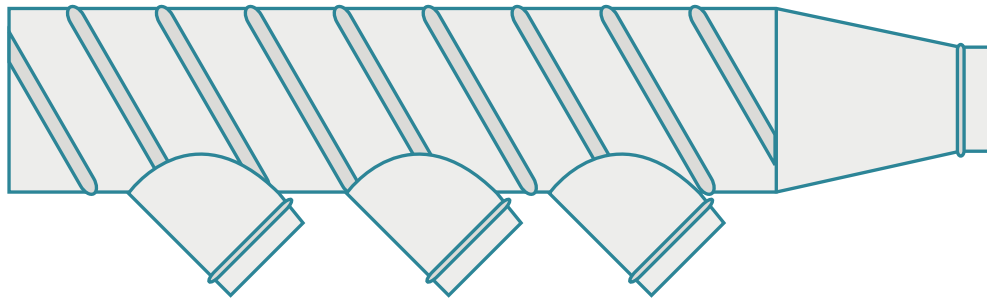
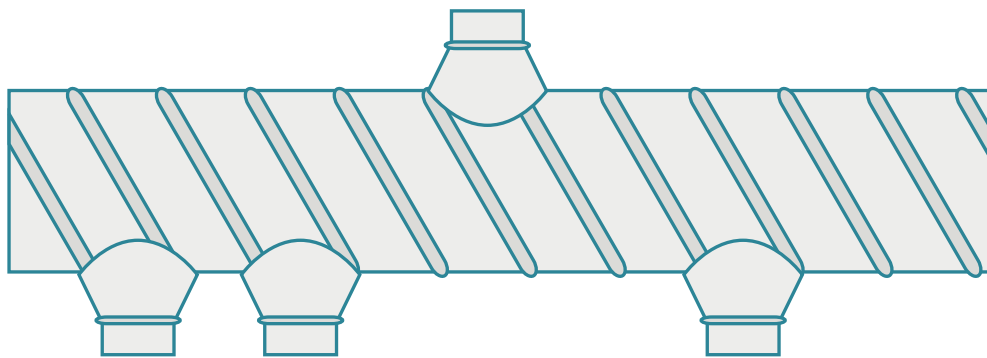

Underground **INSTALLATION**

TAMBE METAL PRODUCTS

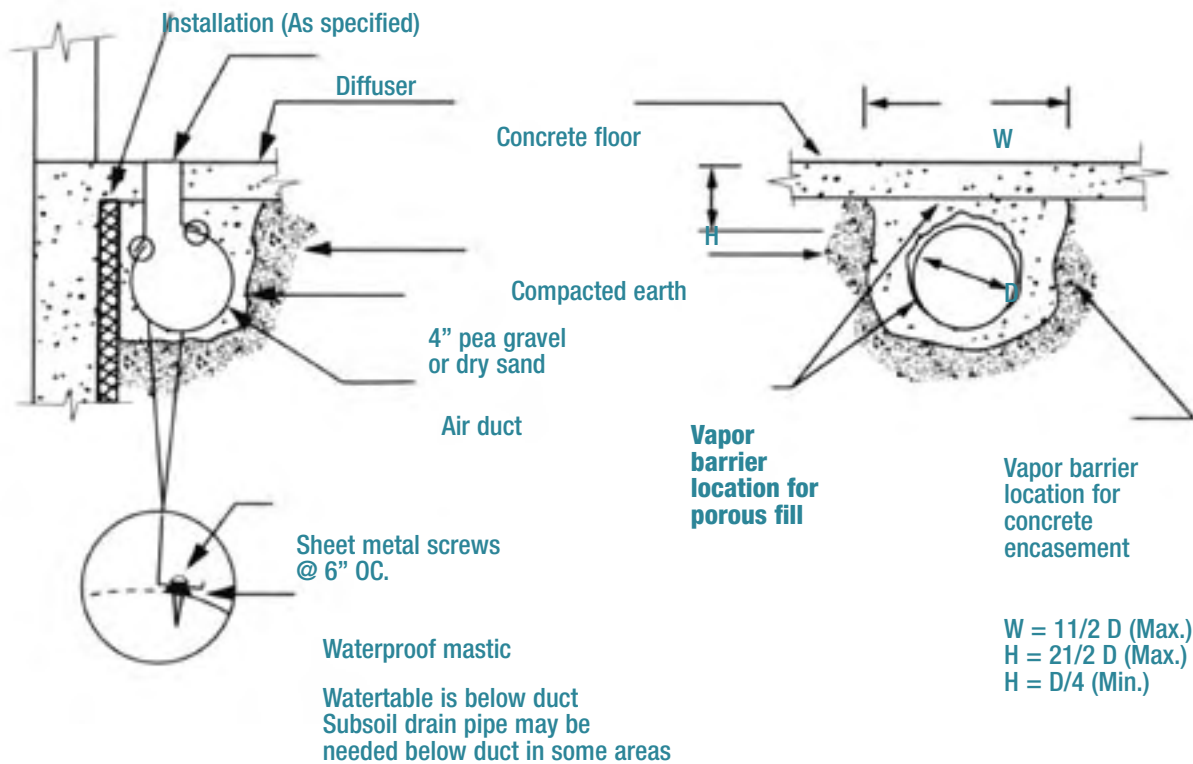
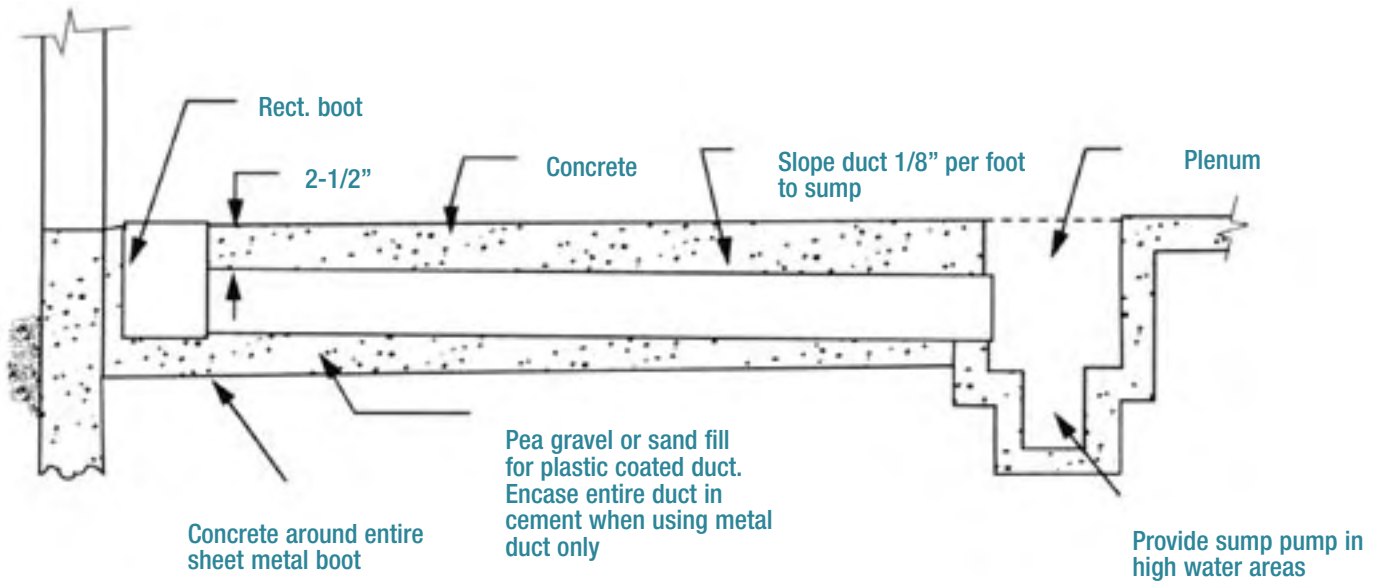

Underground **INSTALLATION**

TAMBE METAL PRODUCTS

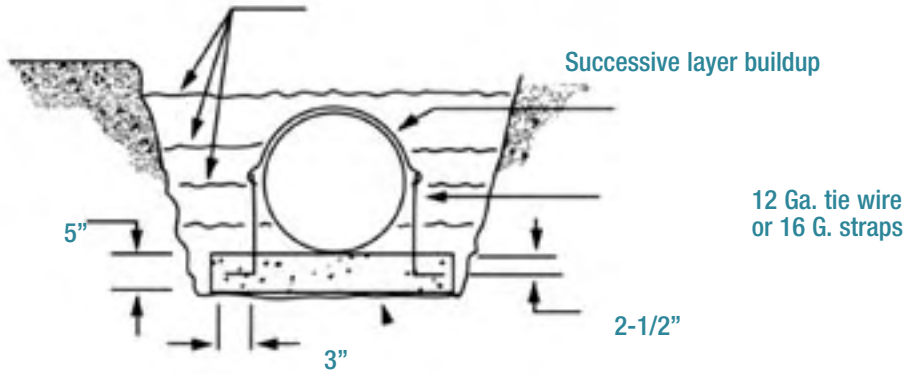

Pre-poured base slab

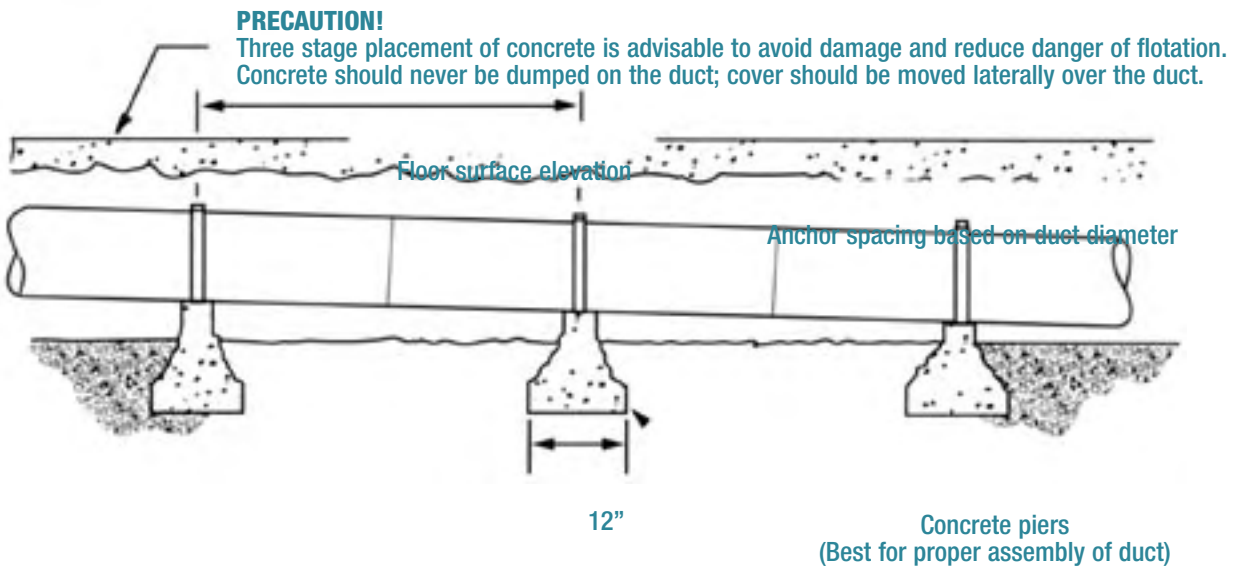

Typical anchorage of ducts to be encased in concrete

* This illustration is a design guide

Approximate Weight **SPIRAL DUCT**

In pounds per linear foot -- Based on galvanized steel

TAMBE METAL PRODUCTS

DIAMETER	WEIGHT PER FOOT					
	26 gauge	24 gauge	22 gauge	20 gauge	18 gauge	16 gauge
3	.76	1.01	1.23	1.48		
4	1.02	1.35	1.64	1.94		
5	1.28	1.69	2.06	2.42		
6	1.54	2.03	2.47	2.91	3.88	4.76
7	1.79	2.37	2.88	3.40	4.52	5.58
8	2.05	2.71	3.29	3.86	5.17	6.34
9	2.31	3.05	3.71	4.37	5.82	7.18
10	2.57	3.39	4.12	4.86	6.47	7.92
11	2.82	3.73	4.54	5.34	7.11	8.72
12	3.08	4.07	4.95	5.83	7.75	9.54
13	3.34	4.41	5.36	6.32	8.48	10.31
14	3.59	4.74	5.77	6.81	9.05	11.05
15	3.84	5.08	6.18	7.28	9.70	11.80
16	4.11	5.42	6.60	7.78	10.34	12.65
17	4.36	5.77	7.02	8.25	11.08	13.47
18	4.63	6.10	7.43	8.76	11.64	14.32
19	4.89	6.44	7.84	9.25	12.29	15.09
20	5.15	6.78	8.25	9.73	12.93	15.85
22	5.65	7.46	9.08	10.71	14.23	17.50
24	6.16	8.14	9.91	11.68	15.52	19.00
26	6.67	8.82	10.73	12.66	16.82	20.70
28	7.18	9.50	11.56	13.63	18.11	22.20
30	7.71	10.18	12.38	14.60	19.41	23.90
32	8.22	10.84	13.21	15.58	20.71	25.50
34	8.72	11.54	14.01	16.51	21.97	27.08
36	9.27	12.20	14.90	17.53	23.29	28.80
38	9.73	12.88	15.67	18.46	24.51	30.26
40	10.30	13.56	16.50	19.48	25.88	31.75
42	10.77	14.25	17.32	20.40	27.21	33.47
44	11.35	14.91	18.16	21.42	28.47	35.00
46	11.86	15.59	18.99	22.39	29.77	36.65
48	12.36	16.26	19.82	23.36	31.06	38.30
50	12.88	16.99	20.63	24.33	32.37	39.94
52	13.39	17.12	21.44	25.30	33.68	41.58
54	13.91	18.05	22.26	26.28	34.98	43.18
56	14.42	18.98	23.08	27.25	36.27	44.78
58	14.94	19.65	23.91	28.23	37.56	46.38
60	15.45	20.34	24.73	29.20	38.84	47.97

Single Wall Round **ELBOWS**

TAMBE METAL PRODUCTS

E90

90° DIE STAMPED ELBOW
3" DIA. THRU 12"

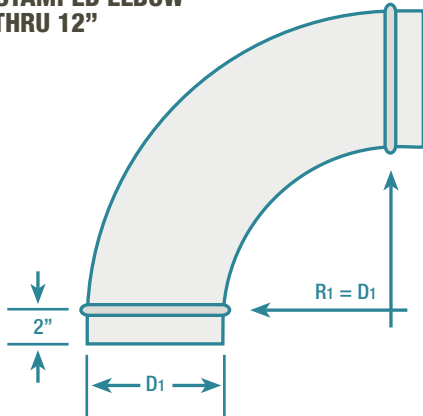

E45

45° DIE STAMPED ELBOW
3" DIA. THRU 12"

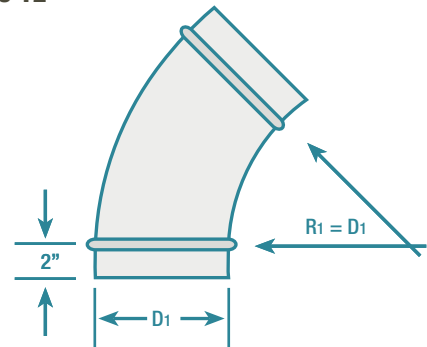

E90

90° 5-PC. ELBOW

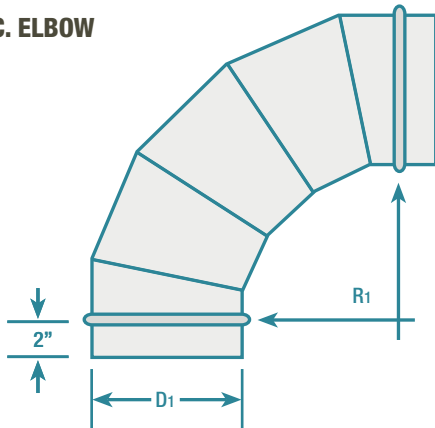

E45

45° 3-PIECE ELBOW

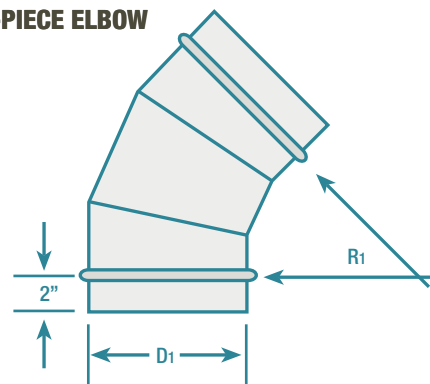

E60

60° 3-PC. ELBOW

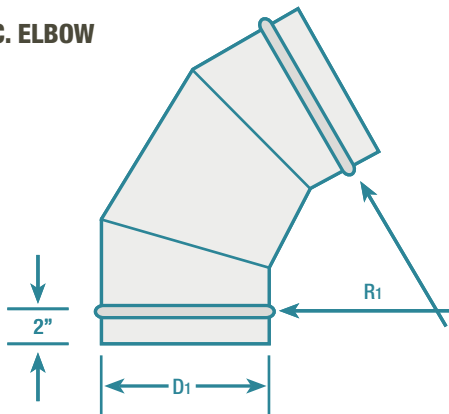

E15/E30

15° & 30° 2-PIECE ELBOW

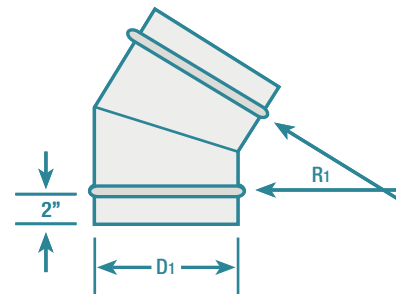

Single Wall Round **ELBOWS**

TAMBE METAL PRODUCTS

90° 3-PC. ELBOW WITH STRAIGHT LATERAL

E90L

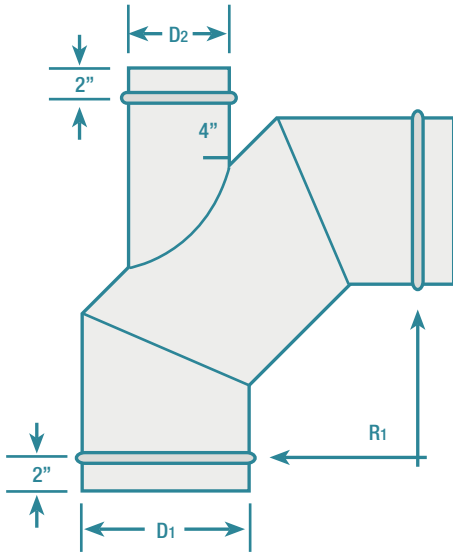

E290/EV290

With or without vanes.

90° 2-PC. ELBOW

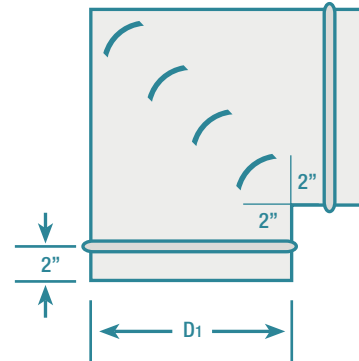

D1	No. of vanes
3-9	2
10-14	3
15-19	4
20-60	5
≥60	Max 12" spacing

E90R

90° 5-PC. ELBOW WITH REDUCER

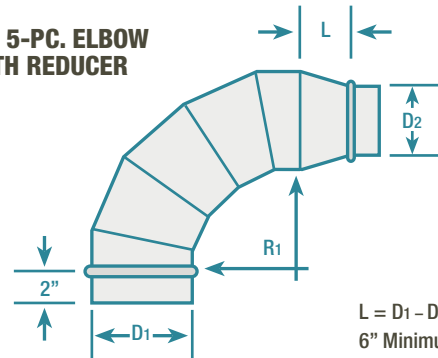

$L = D1 - D2$
6" Minimum

45° 2-PC. ELBOW WITH STRAIGHT LATERAL

E45L

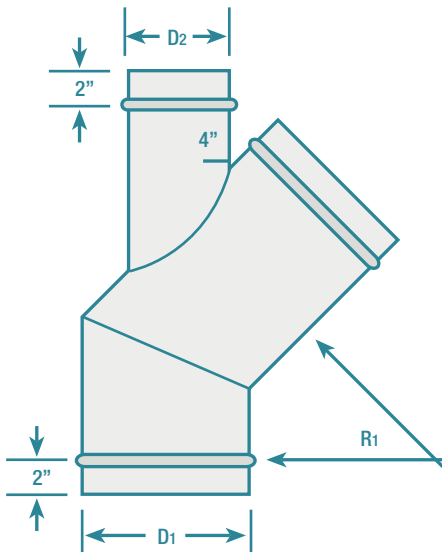

E45R

45° 3-PC. ELBOW WITH REDUCER

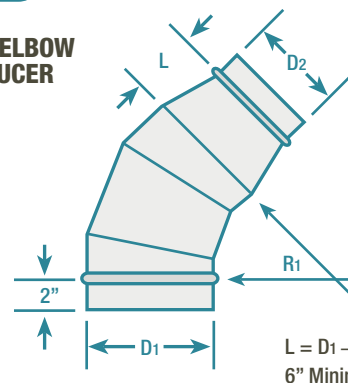

$L = D1 - D2$
6" Minimum

Single Wall Round **STRAIGHT TEES**

TAMBE METAL PRODUCTS

T

TEE

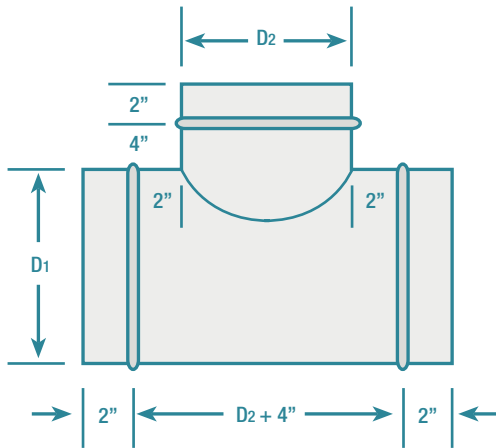

TR

REDUCING TEE

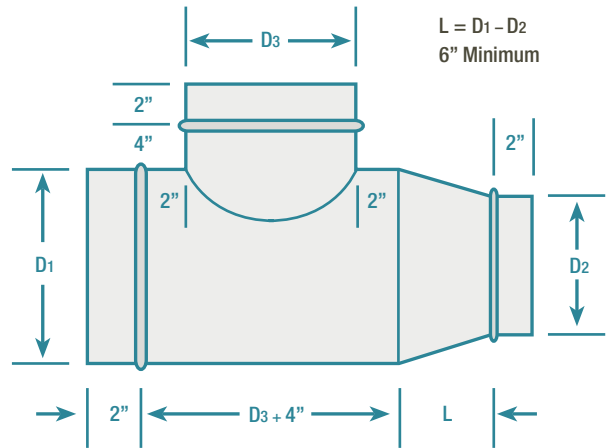

TX

TEE CROSS

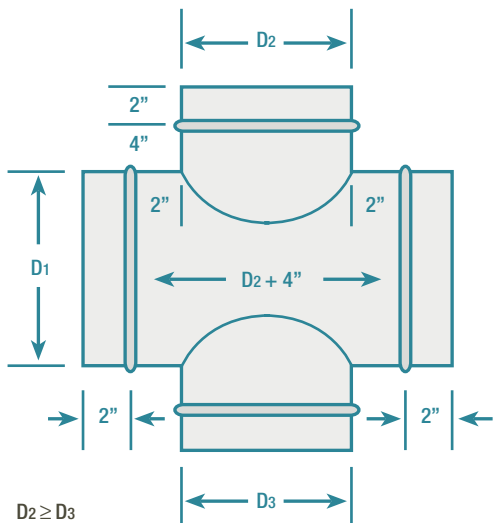

TRX

REDUCING TEE CROSS

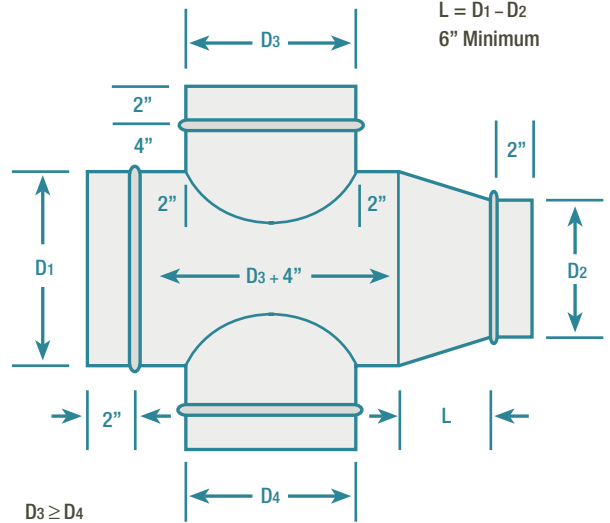

Single Wall Round CONICAL TEES

TAMBE METAL PRODUCTS

CT

CONICAL TEE

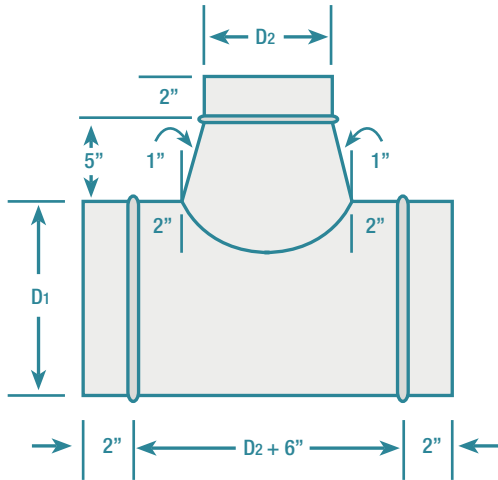

CTR

REDUCING CONICAL TEE

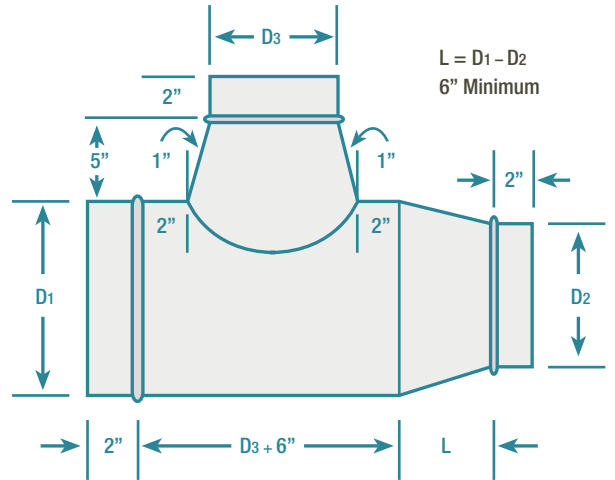

CTX

CONICAL TEE CROSS

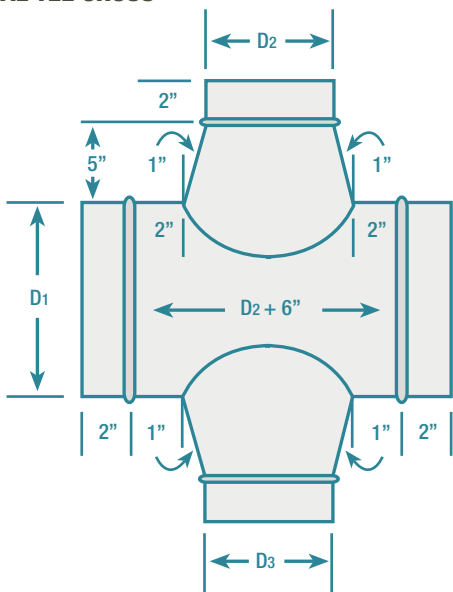

$D_2 \geq D_3$

CTRX

REDUCING CONICAL TEE CROSS

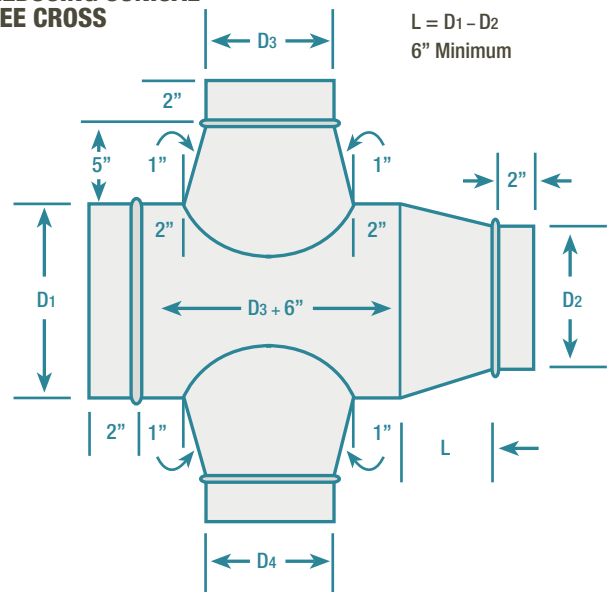

$D_3 \geq D_4$

Single Wall Round **SHOE TEES**

TAMBE METAL PRODUCTS

ST

SHOE TEE

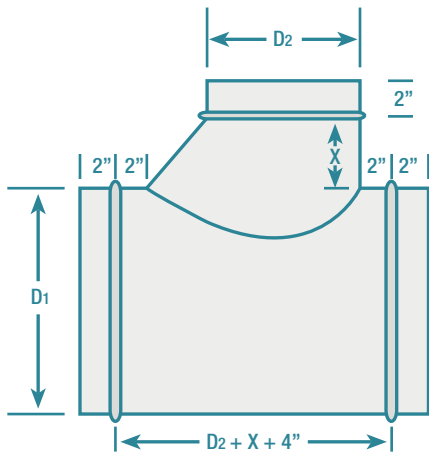

D2	X
3 thru 8	5"
9 thru 16	7"
17 thru 26	10"
27" and up	13"

STR

REDUCING SHOE TEE

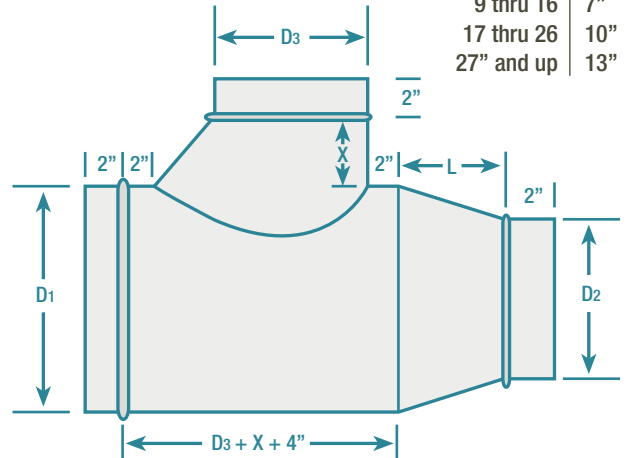

D3	X
3 thru 8	5"
9 thru 16	7"
17 thru 26	10"
27" and up	13"

$L = D1 - D2$
Minimum 6"

STX

SHOE TEE CROSS

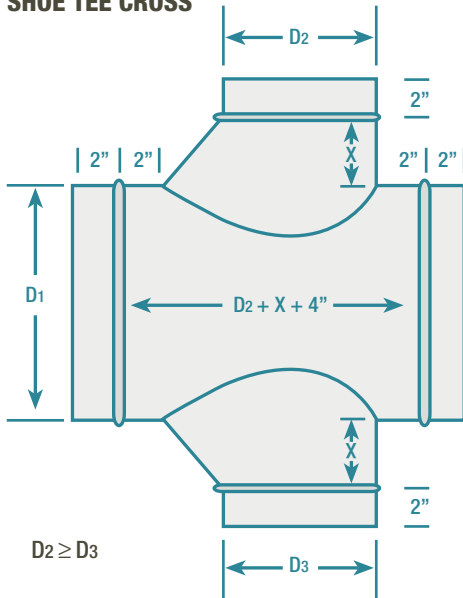

D2, D3	X
3 thru 8	5"
9 thru 16	7"
17 thru 26	10"
27" and up	13"

STRX

REDUCING SHOE TEE CROSS

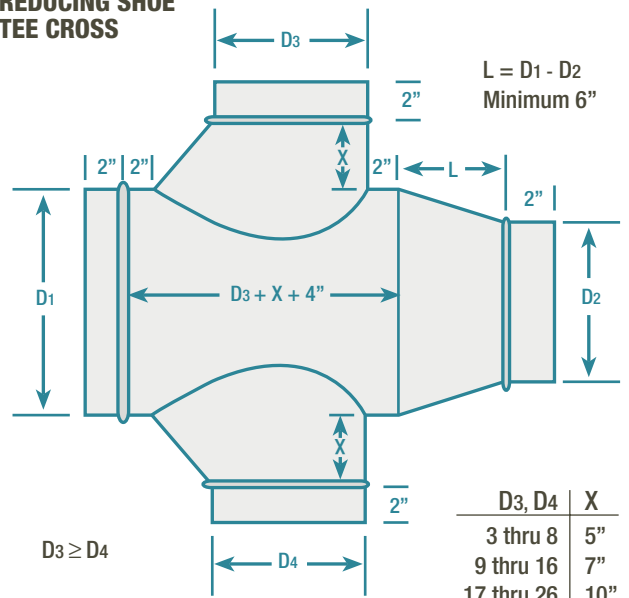

$L = D1 - D2$
Minimum 6"

D3, D4	X
3 thru 8	5"
9 thru 16	7"
17 thru 26	10"
27" and up	13"

Single Wall Round STRAIGHT LATERALS

TAMBE METAL PRODUCTS

L

45° LATERAL

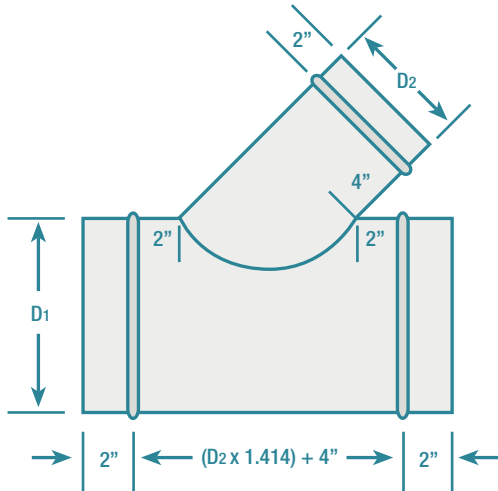

LR

45° REDUCING LATERAL

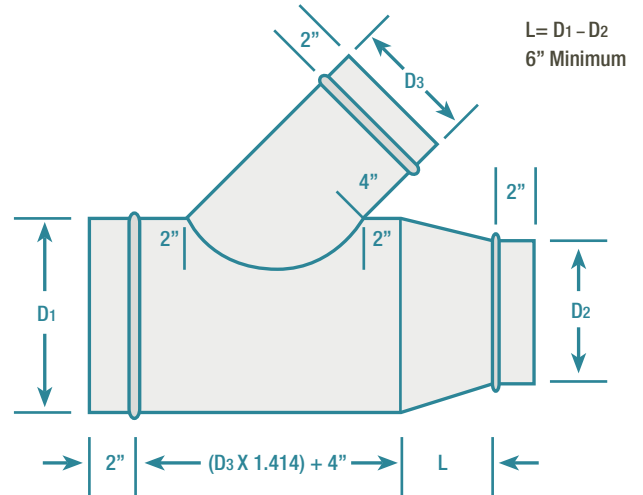

LX

45° LATERAL CROSS

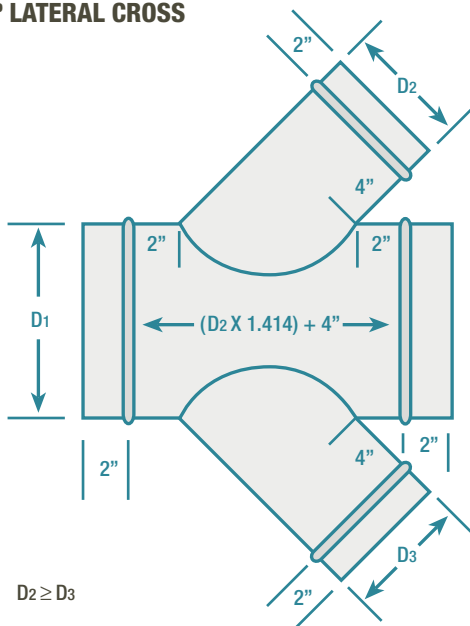

LRX

45° REDUCING LATERAL CROSS

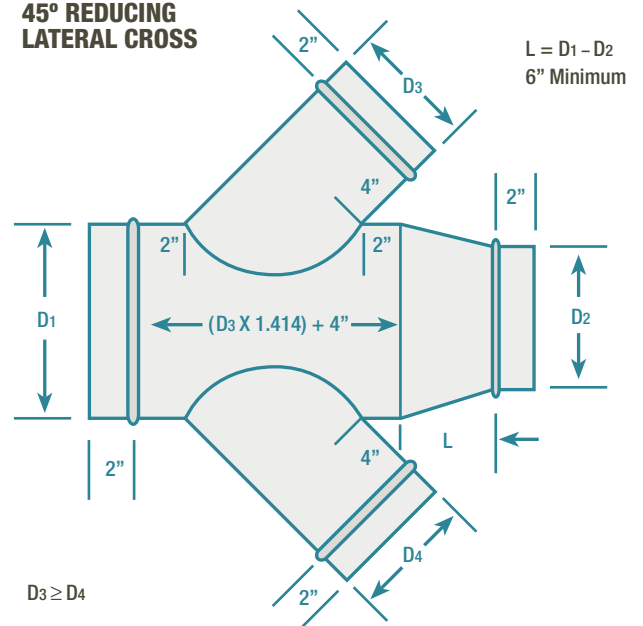

Single Wall Round CONICAL LATERALS

TAMBE METAL PRODUCTS

CL

45° CONICAL LATERAL

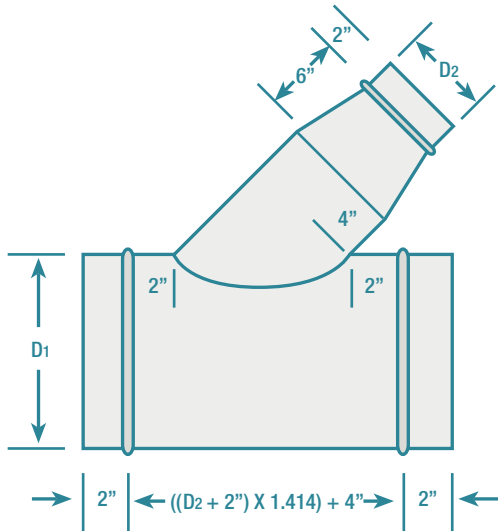

CLR

45° REDUCING CONICAL LATERAL

$L = D_1 - D_2$
6" Minimum

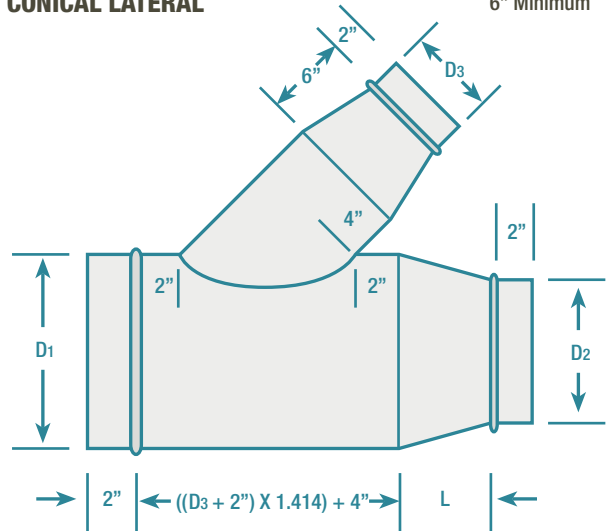

CLX

45° CONICAL LATERAL CROSS

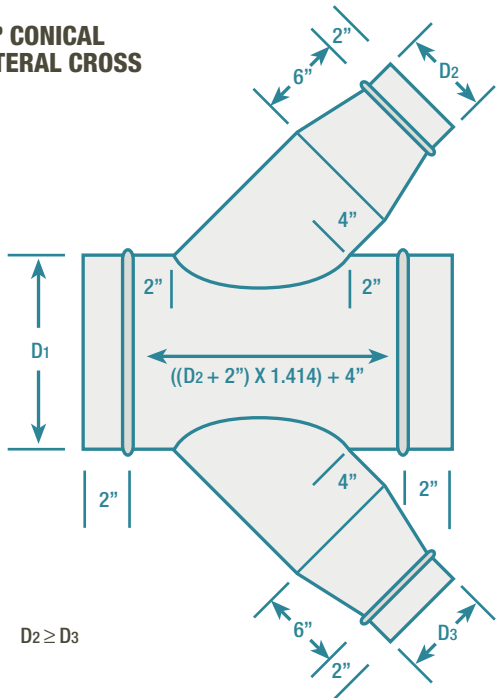

CLR X

45° REDUCING CONICAL LATERAL CROSS

$L = D_1 - D_2$
6" Minimum

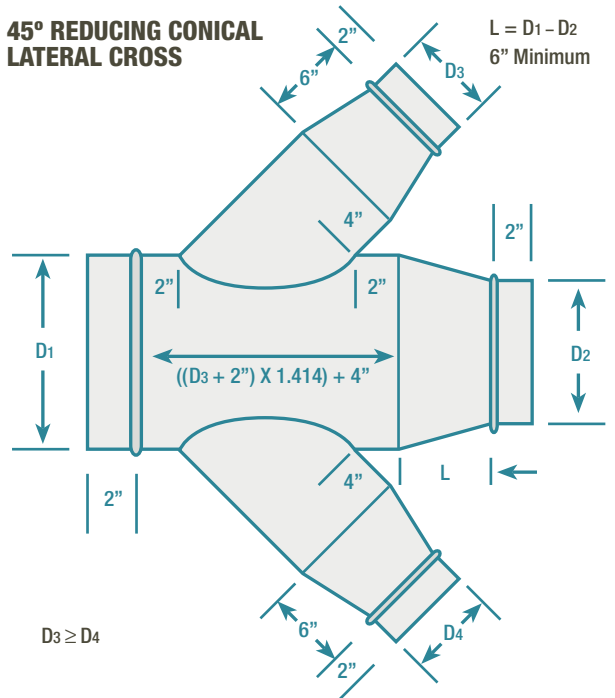

Single Wall Round MISCELLANEOUS

TAMBE METAL PRODUCTS

RDC

CONCENTRIC REDUCER

$$L = D_1 - D_2$$

6" Minimum

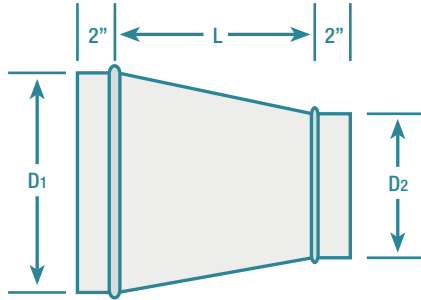

RDE

ECCENTRIC REDUCER

$$L = 2 [D_1 - D_2]$$

6" Minimum

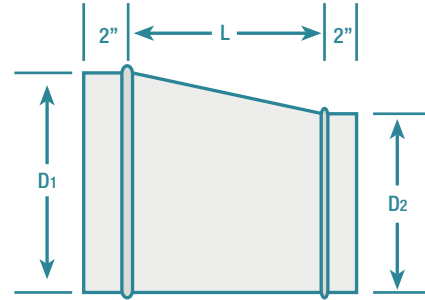

PC

PIPE COUPLING

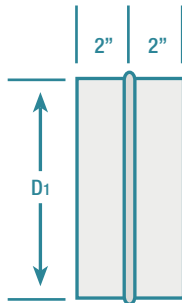

FC

FITTING COUPLING

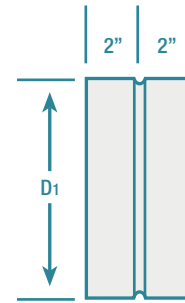

RTR

RECTANGLE TO ROUND

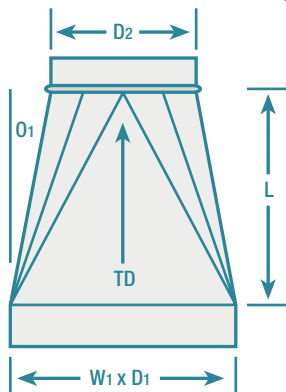

EC

END CAP

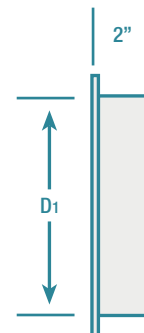

Single Wall Round MISCELLANEOUS

TAMBE METAL PRODUCTS

SET

OFFSET

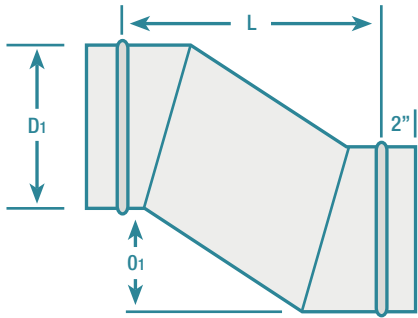

ROET

ROUND TO ROUND

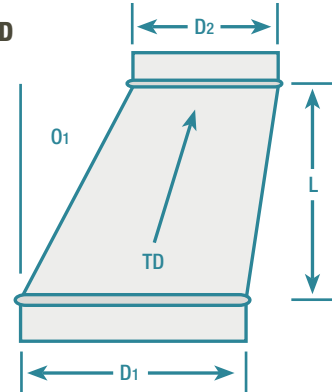

Y45

Y BRANCH

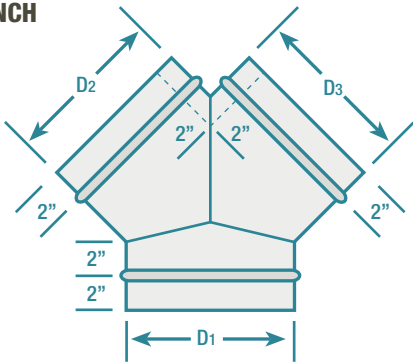

YR45

REDUCING Y BRANCH

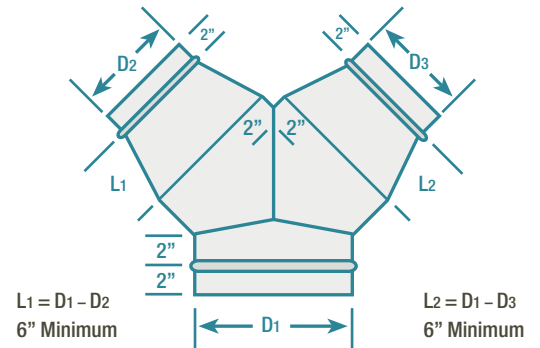

BHT/BHTV

BULL HEAD TEE With or without vanes.

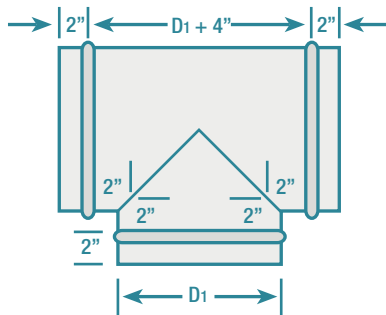

D1	No. of vanes
3-7	1
8-10	3
10-60	5
>60	Max 12" spacing

BHTR/BHTRV

REDUCING BULL HEAD TEE With or without vanes.

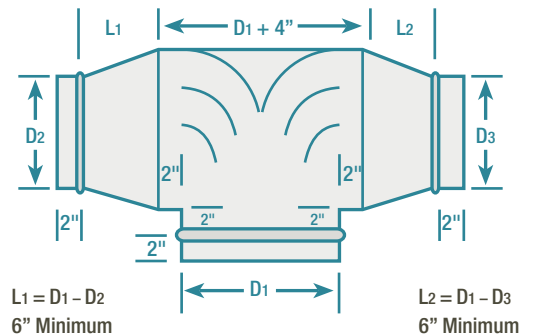

Shop/Field Installed **ACCESSORIES**

TAMBE METAL PRODUCTS

TAP

TAP 90

Standard flange is 1/2".
2" saddle is also available.

CONICAL TAP

CTAP 90

Standard flange is 1/2".
2" saddle is also available.

LATERAL TAP

TAP 45

Standard flange is 1/2". 2" saddle is also available.

SHOE TAP

D2	L
3 thru 8	5"
9 thru 16	7"
17 thru 26	10"
27" and up	13"

Standard flange is 1/2". 2" saddle is also available.

REGISTER TAP

RECTAP

Flange in or out

1/2" Flange

ACCESS DOOR

ADOOR

Double Wall Round **ELBOWS**

TAMBE METAL PRODUCTS

E90

90° DIE STAMPED ELBOW
3" DIA. THRU 12"

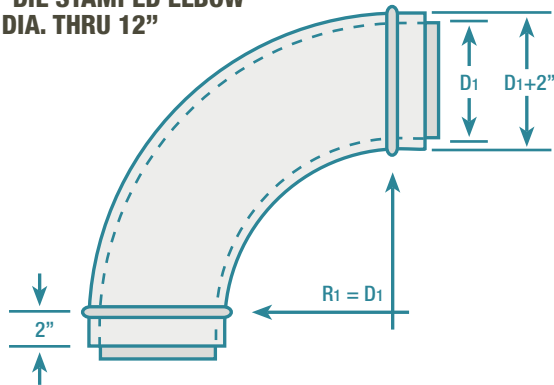

E45

45° DIE STAMPED ELBOW
3" DIA. THRU 12"

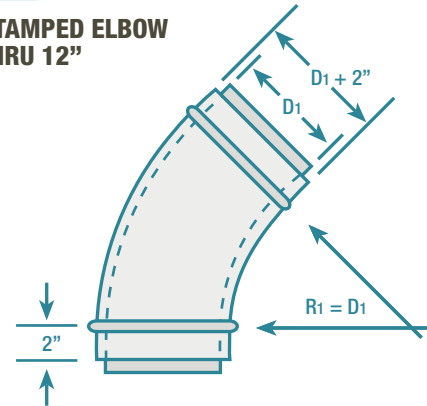

E90

90° 5-PC. ELBOW

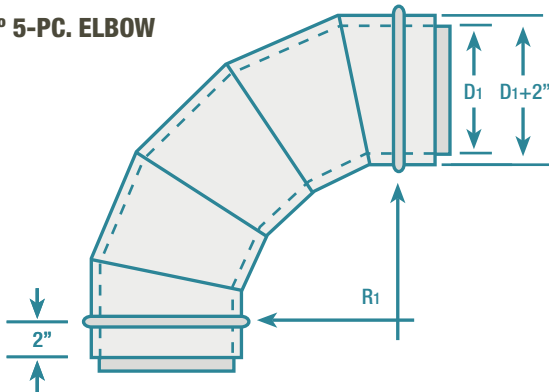

E45

45° 3-PIECE ELBOW

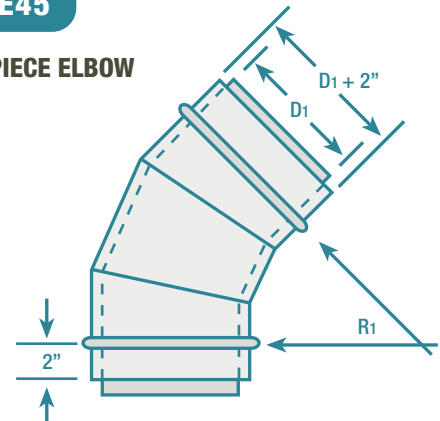

E60

60° 3-PC. ELBOW

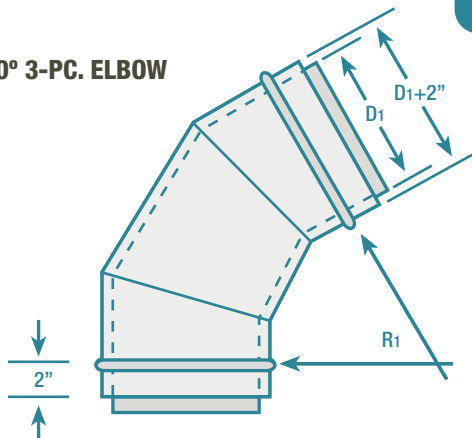

E15/E30

15° & 30°
2-PIECE ELBOW

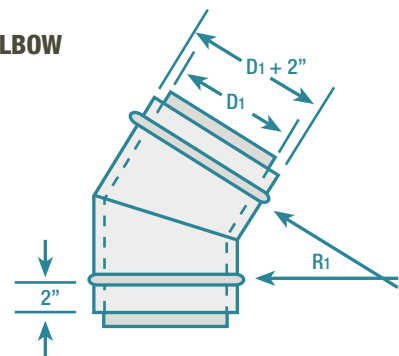

Double Wall Round **ELBOWS**

TAMBE METAL PRODUCTS

90° 3-PC. ELBOW WITH STRAIGHT LATERAL

E90L

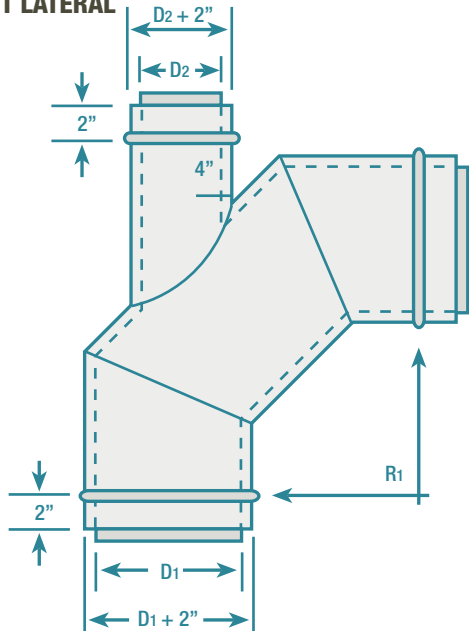

E290/EV290

90° 2-PC. ELBOW

With or without vanes.

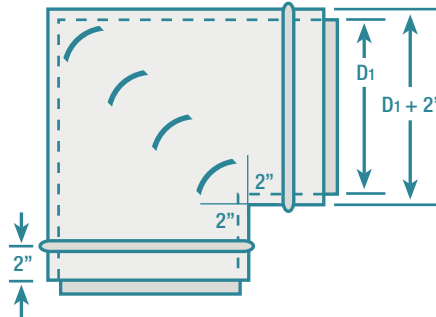

D1	No. of vanes
3-9	2
10-14	3
15-19	4
20-60	5
≥60	Max 12" spacing

45° 2-PC. ELBOW WITH STRAIGHT LATERAL

E45L

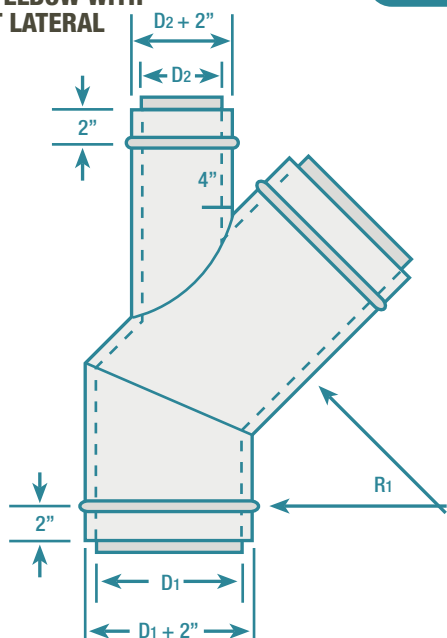

90° 5-PC. ELBOW WITH REDUCER

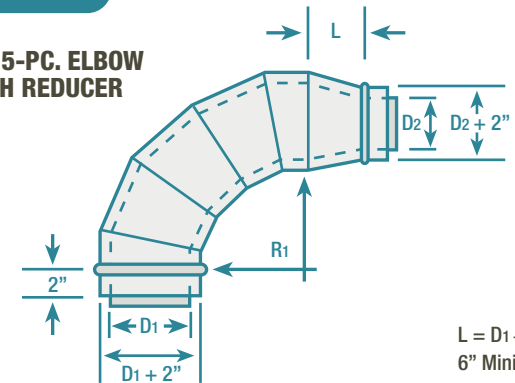

$L = D1 - D2$
6" Minimum

45° 3-PC. ELBOW WITH REDUCER

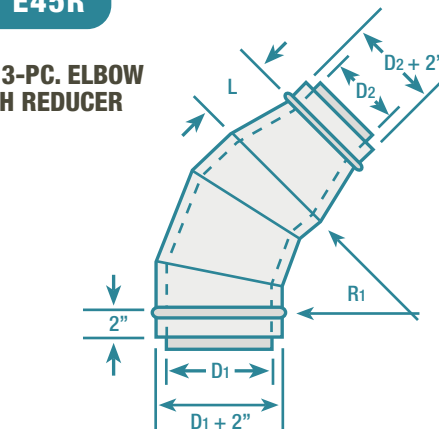

$L = D1 - D2$
6" Minimum

Double Wall Round CONICAL TEES

TAMBE METAL PRODUCTS

CT

CONICAL TEE

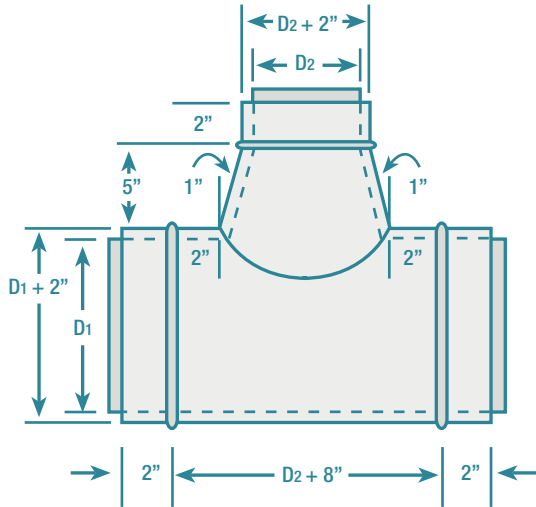

CTR

REDUCING CONICAL TEE

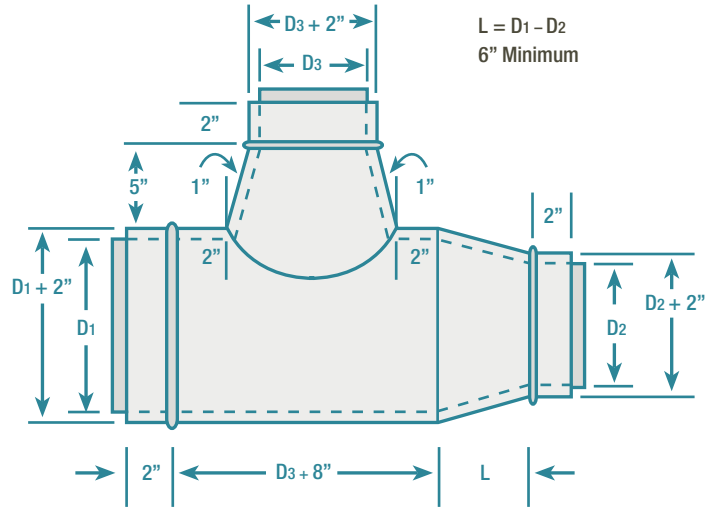

CTX

CONICAL CROSS

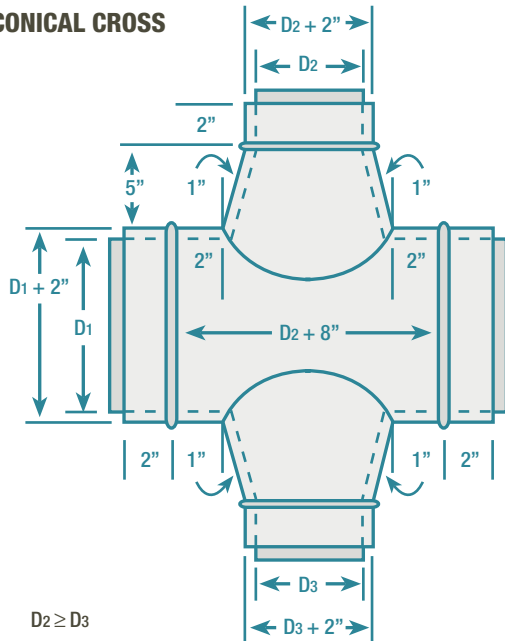

CTRX

REDUCING CONICAL CROSS

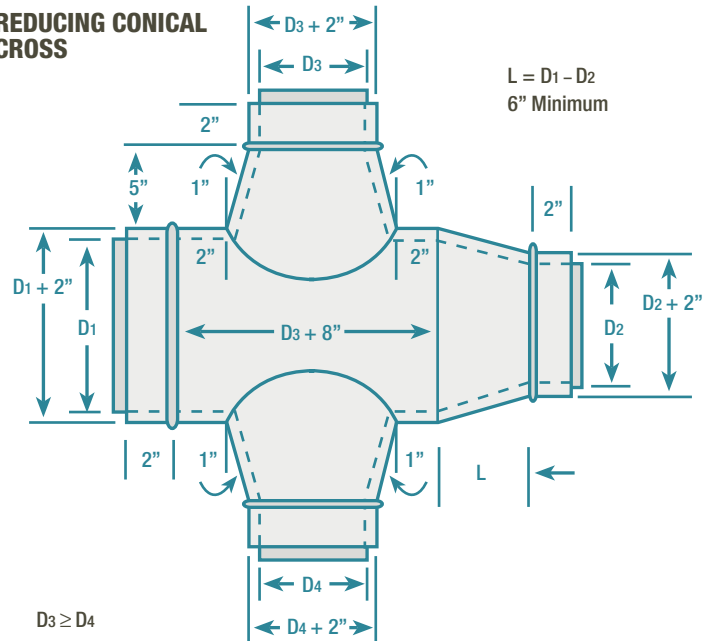

Double Wall Round **SHOE TEES**

TAMBE METAL PRODUCTS

ST

SHOE TEE

D2	X
3 thru 8	5"
9 thru 16	7"
17 thru 26	10"
27" and up	13"

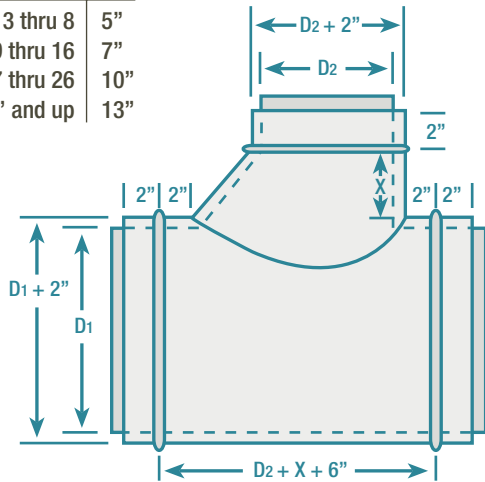

STR

REDUCING SHOE TEE

D3	X
3 thru 8	5"
9 thru 16	7"
17 thru 26	10"
27" and up	13"

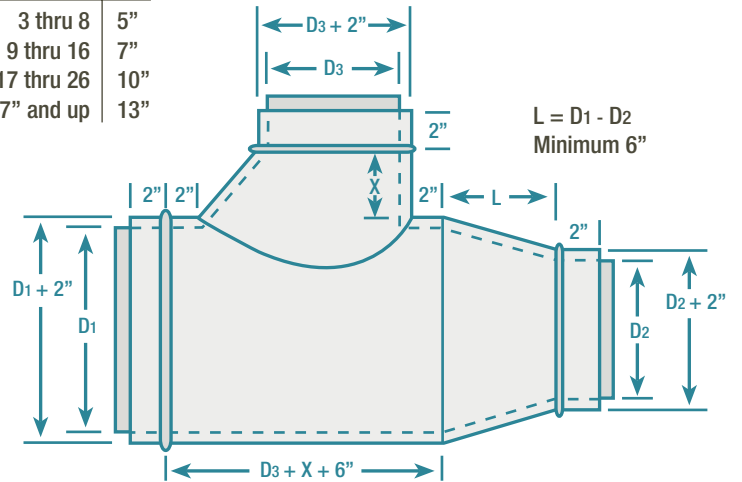

STX

SHOE TEE CROSS

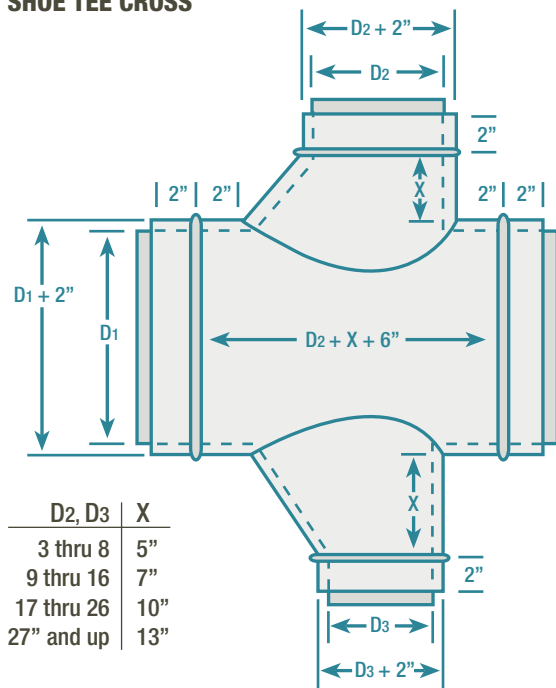

D2, D3	X
3 thru 8	5"
9 thru 16	7"
17 thru 26	10"
27" and up	13"

D2 ≥ D3

STRX

REDUCING SHOE TEE CROSS

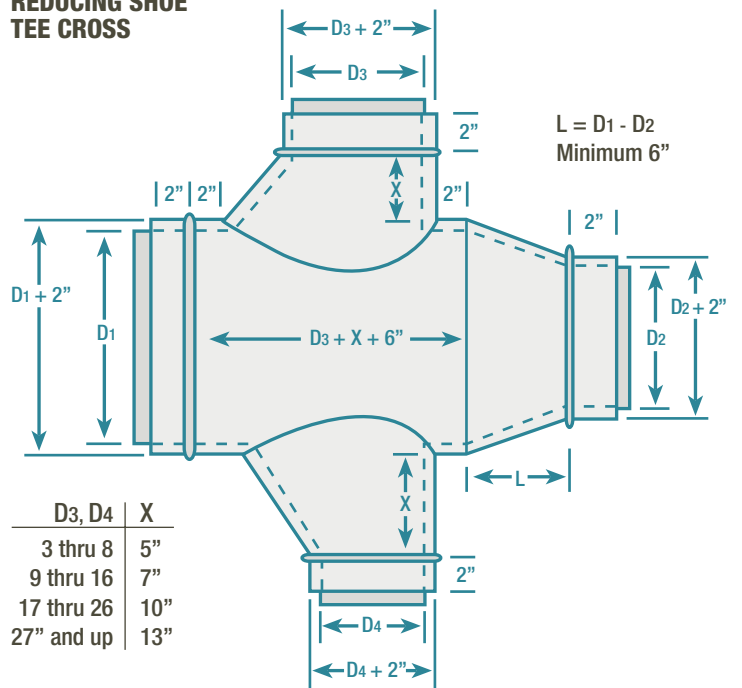

D3, D4	X
3 thru 8	5"
9 thru 16	7"
17 thru 26	10"
27" and up	13"

D3 ≥ D4

Double Wall Round STRAIGHT LATERALS

TAMBE METAL PRODUCTS

L

45° LATERAL

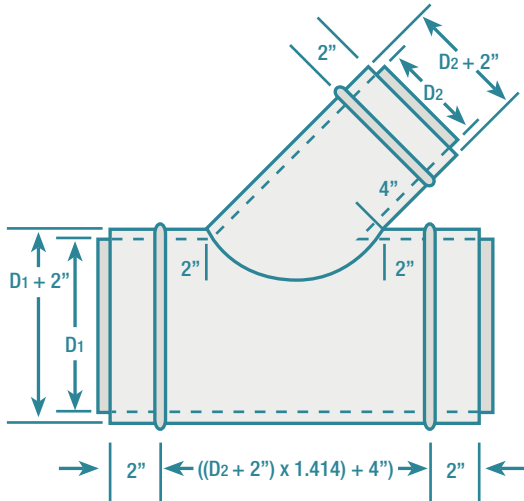

LR

45° REDUCING LATERAL

$L = D_1 - D_2$
6" Minimum

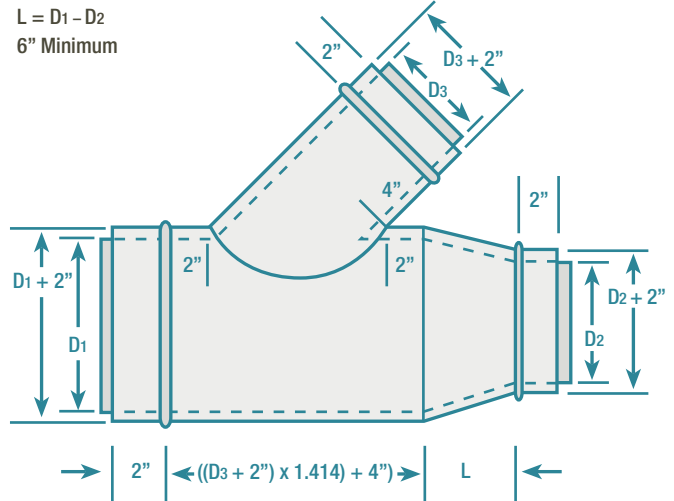

LX

45° LATERAL CROSS

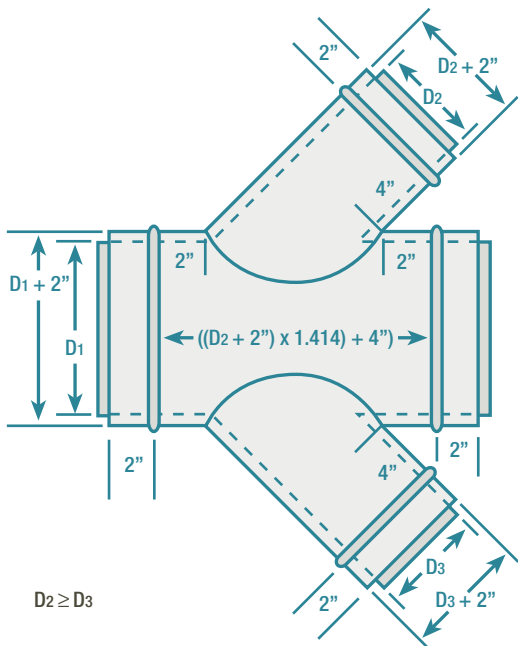

LRX

45° REDUCING LATERAL CROSS

$L = D_1 - D_2$
6" Minimum

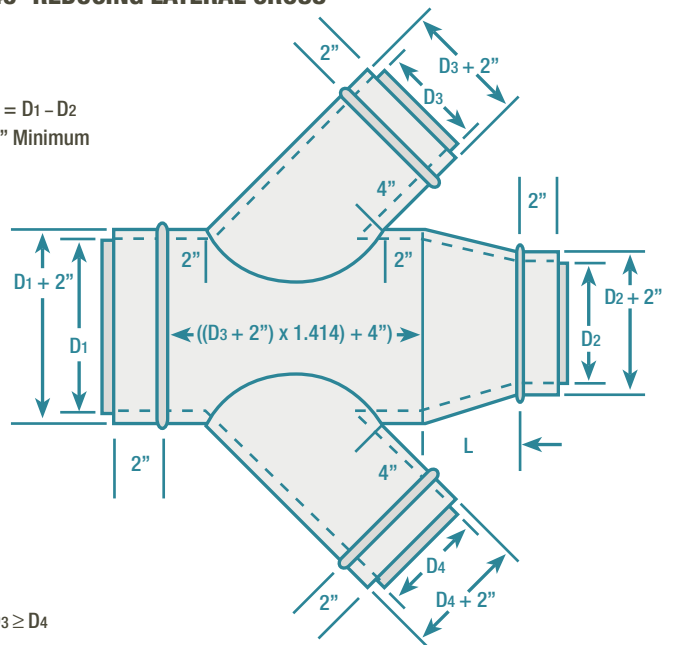

Double Wall Round CONICAL LATERALS

TAMBE METAL PRODUCTS

CL

45° CONICAL LATERAL

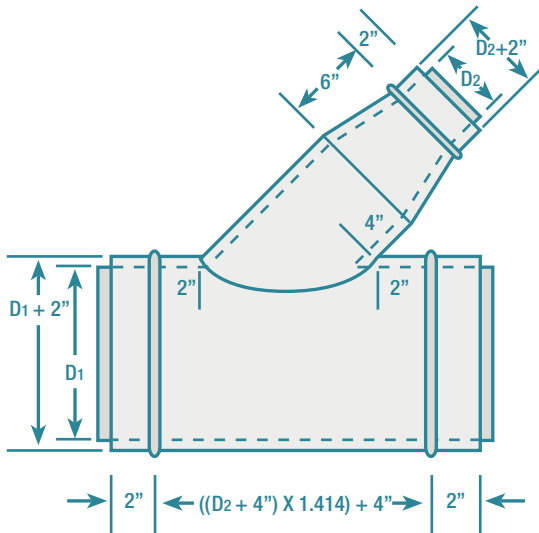

CLR

45° REDUCING CONICAL LATERAL

$L = D_1 - D_2$
6" Minimum

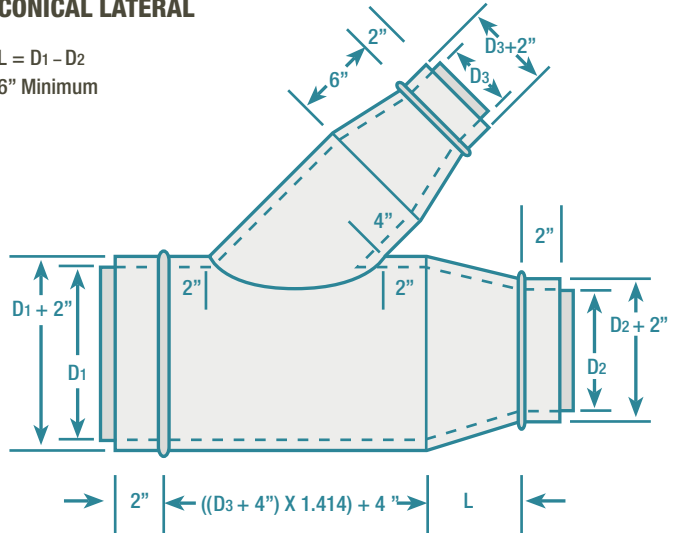

CLX

45° CONICAL LATERAL CROSS

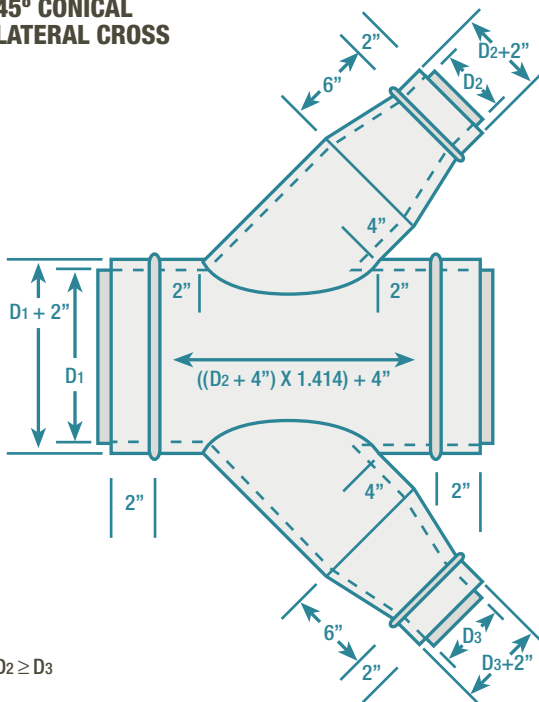

CLR X

45° REDUCING CONICAL LATERAL CROSS

$L = D_1 - D_2$
6" Minimum

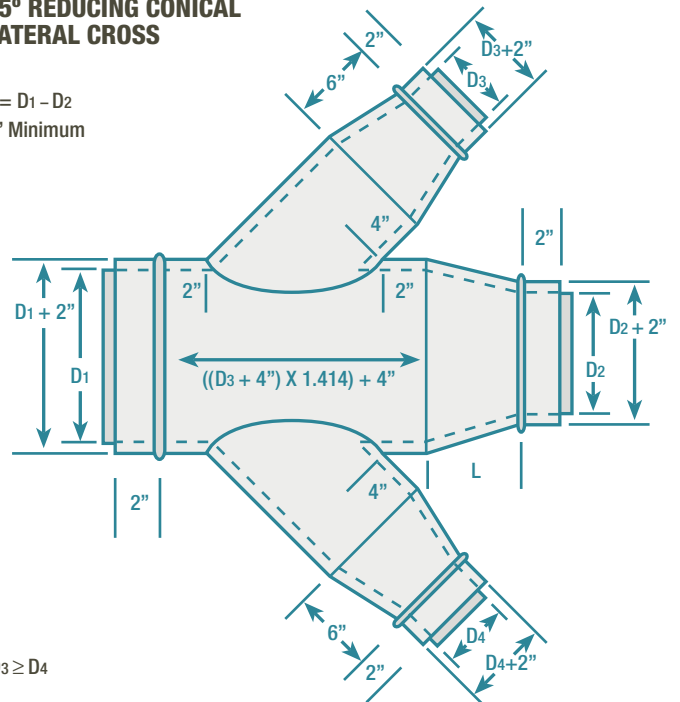

Double Wall Round MISCELLANEOUS

TAMBE METAL PRODUCTS

RDC

CONCENTRIC REDUCER

$$L = D_1 - D_2$$

6" Minimum

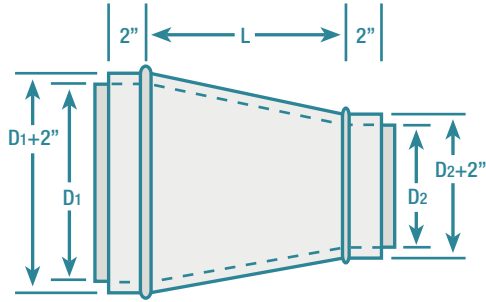

RDE

ECCENTRIC REDUCER

$$L = 2 [D_1 - D_2]$$

6" Minimum

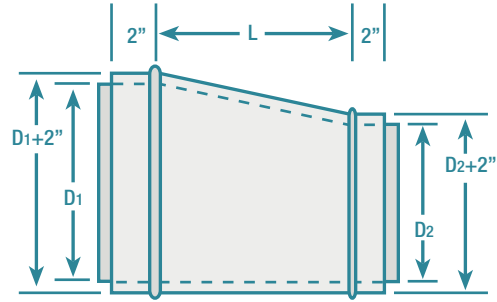

PC

PIPE COUPLING

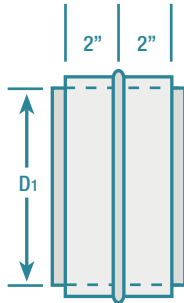

FC

FITTING COUPLING

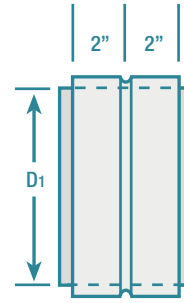

RTR

RECTANGLE TO ROUND

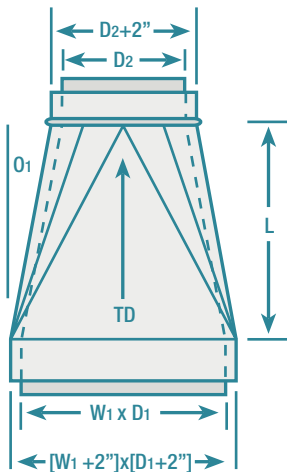

EC

END CAP

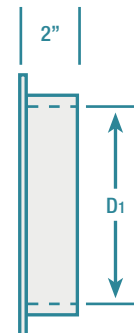

Double Wall Round MISCELLANEOUS

TAMBE METAL PRODUCTS

SET

OFFSET

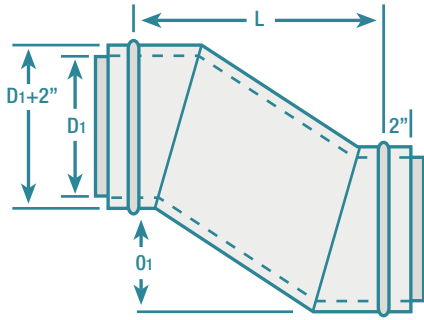

ROET

ROUND TO ROUND

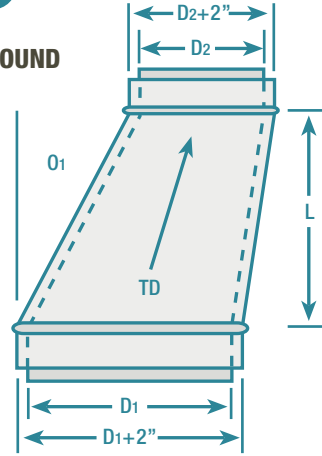

Y45

Y BRANCH

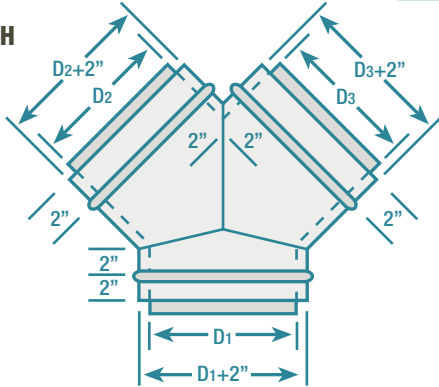

YR45

REDUCING Y BRANCH

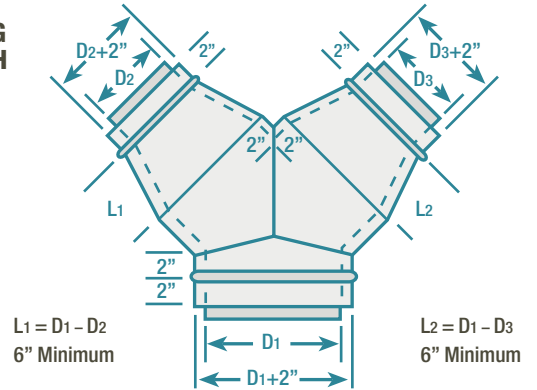

BHT/BHTV

BULL HEAD TEE With or without vanes.

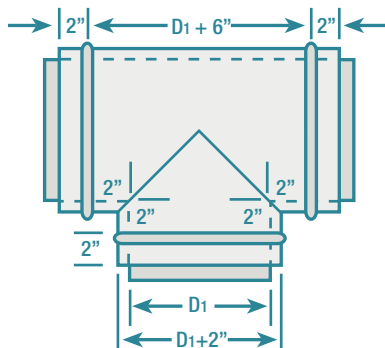

D1	No. of vanes
3-7	1
8-10	3
10-60	5
>60	Max 12" spacing

BHTR/BHTRV

REDUCING BULL HEAD TEE With or without vanes.

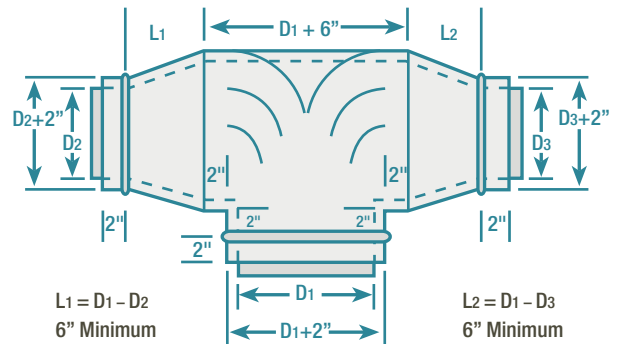

Shop/Field Installed **ACCESSORIES**

TAMBE METAL PRODUCTS

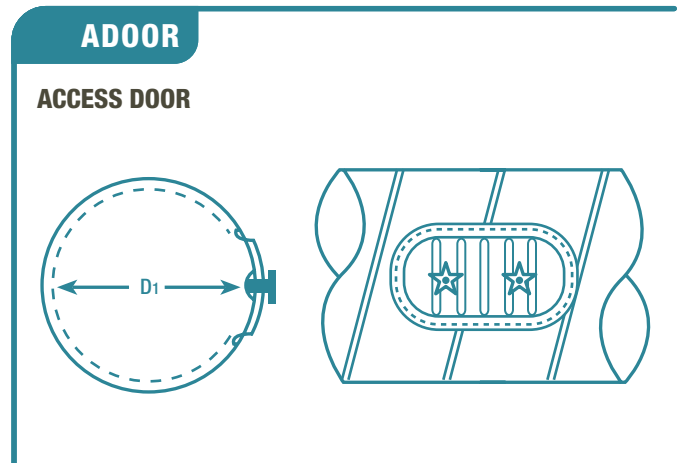
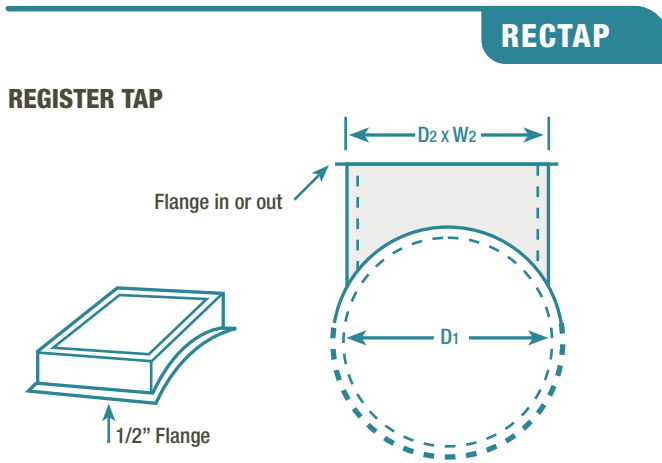
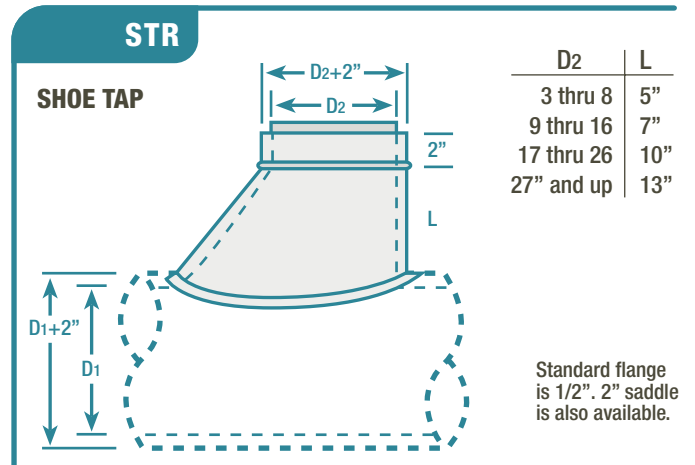
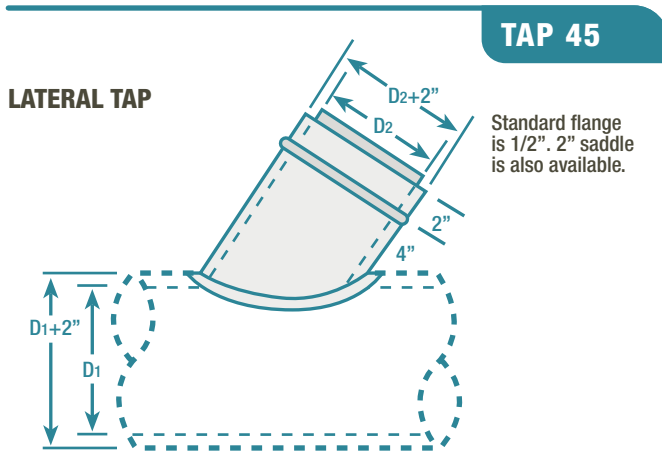
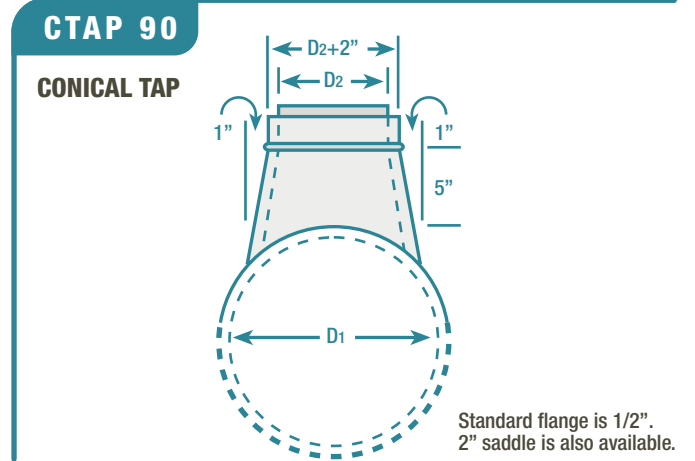
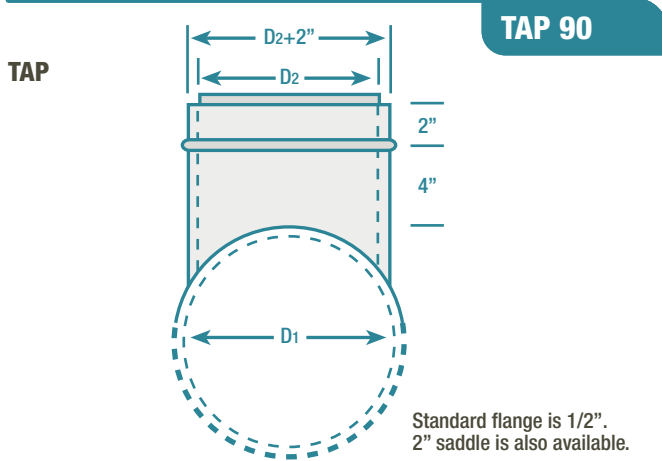

OVAL DUCT SYSTEMS

TAMBE METAL PRODUCTS

Flat oval duct combines the advantages of round duct and rectangular duct because it may fit in spaces where there is not enough room for round duct, and it can be joined using the techniques of round duct assembly.

Spiral flat oval duct is machine-made from round spiral lockseam duct and is available in varying sizes and aspect ratios. It can be made with longitudinal seams.

Flat oval duct has considerably less flat surface that is susceptible to vibration and requires less reinforcement than a corresponding size of rectangular duct. The deflection of the flat oval duct under pressure is related to the flat span rather than the overall width of the duct.

Any round duct fitting can have an equivalent fitting made in flat oval. As in rectangular duct, a hard bend elbow denotes the plane of the duct width, whereas an easy bend elbow denotes the bend in the plane of the duct height. Any branch fitting can be made with the branch tap either round or flat oval. The tap of the flat oval fitting can be located anywhere on the circumference of the fitting body. If the diameter of a round tap is greater than the height of the flat oval body, a transition can be made from flat oval to round, providing an equivalent area at the base of the transition.

Flat oval duct is for positive pressure applications only unless special designs are used.



Oval Duct CONSTRUCTION STANDARDS

TAMBE METAL PRODUCTS

FLAT OVAL DUCT CONSTRUCTION

Major Dimension Duct Width	Spiral Seam Duct Gauge	Longitudinal Seam Duct Gauge	Gauge of Fittings
to 24"	24	20	20
25 to 36"	22	20	20
37 to 48"	22	18	18
49 to 60"	20	18	18
61 to 70"	20	16	16
71" and up	18	16	16

* Initial spiral sizes indicated are for fabrication purposes only. For conversion from rectangular or round to oval, consult factory.

Nominal flat oval pipe sizes

* INITIAL SPIRAL SIZE	MINOR AXIS																MAJOR AXIS
	6	8	10	12	14	16	18	20	22	24	26	28	30	32	34	36	
15	20																
16	22																
17	23	22	21	20	19												
18	25	24	23	21	20	19											
19	26	25	24	23	22	21											
20	28	27	26	25	23	22	21										
22	31	30	29	28	27	25	24	23									
24	34	33	32	31	30	29	27	26	25								
26	37	36	35	34	33	32	31	29	28	27							
28	41	39	38	37	36	35	34	33	31	30							
30	44	42	41	40	39	38	37	36	35	33	32						
32	47	46	45	43	42	41	40	39	38	37	35	34					
34	50	49	48	47	45	44	43	42	41	40	39	37	36				
36	53	52	51	50	49	47	46	45	44	43	42	41	39	38			
38	56	55	54	53	52	51	49	48	47	46	45	44	43	41	40		
40	59	58	57	56	55	54	53	51	50	49	48	47	46	45	43	42	
42	63	61	60	59	58	57	56	55	53	52	51	50	49	48	47	45	
44	66	65	63	62	61	60	59	58	57	55	54	53	52	51	50	49	
46	69	68	67	65	64	63	62	61	60	59	57	56	55	54	53	52	
48	72	71	70	69	67	66	65	64	63	62	61	59	58	57	56	55	
50		74	73	72	71	69	68	67	66	65	64	63	61	60	59	58	
52				75	74	73	71	70	69	68	67	66	65	63	62	61	
54						76	75	73	72	71	70	69	68	67	65	64	
56						79	78	77	75	74	73	72	71	70	69	67	
58							81	80	79	77	76	75	74	73	72	71	
60									82	81	79	78	77	76	75	74	
62										85	84	83	81	80	79	78	77
64											86	85	83	82	81	80	
66													87	85	84	83	
68														89	87	86	
70															91	89	
72																93	

Oval Duct CONSTRUCTION STANDARDS

TAMBE METAL PRODUCTS

Actual flat oval pipe sizes

INITIAL SPIRAL SIZE	MINOR AXIS																MAJOR AXIS
	6	8	10	12	14	16	18	20	22	24	26	28	30	32	34	36	
15	20.14																
16	21.71																
17	23.28	22.14	21.00	19.85	18.71												
18	24.85	23.71	22.57	21.42	20.28	19.14											
19	26.42	25.28	24.14	23.00	21.85	20.71											
20	27.99	26.85	25.71	24.57	23.42	22.28	21.14										
22	31.13	29.99	28.85	27.71	26.57	25.42	24.28	23.14									
24	34.27	33.13	31.99	30.85	29.71	28.57	27.42	26.28	25.14								
26	37.42	36.27	35.13	33.99	32.85	31.71	30.57	29.42	28.28	27.14							
28	40.56	39.42	38.27	37.13	35.99	34.85	33.71	32.57	31.42	30.28							
30	43.70	42.56	41.42	40.27	39.13	37.99	36.85	35.71	34.57	33.42	32.28						
32	46.84	45.70	44.56	43.42	42.27	41.13	39.99	38.85	37.71	36.57	35.42	34.28					
34	49.98	48.84	47.70	46.56	45.42	44.27	43.13	41.99	40.85	39.71	38.57	37.42	36.28				
36	53.12	51.98	50.84	49.70	48.56	47.42	46.27	45.13	43.99	42.85	41.71	40.57	39.42	38.28			
38	56.27	55.12	53.98	52.84	51.70	50.56	49.42	48.27	47.13	45.99	44.85	43.71	42.57	41.42	40.28		
40	59.41	58.27	57.12	55.98	54.84	53.70	52.56	51.42	50.27	49.13	47.99	46.85	45.71	44.57	43.42	42.28	
42	62.55	61.41	60.27	59.12	57.98	56.84	55.70	54.56	53.42	52.27	51.13	49.99	48.85	47.71	46.57	45.42	
44	65.69	64.55	63.41	62.27	61.12	59.98	58.84	57.70	56.56	55.42	54.27	53.13	51.99			49.71	48.57
46	68.83	67.69	66.55	65.41	64.27	63.12	61.98	60.84	59.70	58.56	57.42	56.27	55.13			52.85	51.71
48	71.87	70.83	69.69	68.55	67.41	66.27	65.12	63.98	62.84	61.70	60.56	59.42	58.27			55.99	54.85
50		73.97	72.83	71.69	70.55	69.41	68.27	67.12	65.98	64.84	63.70	62.56	61.42			59.13	57.99
52				74.83	73.69	72.55	71.41	70.27	69.12	67.98	66.84	65.70	64.56			62.27	61.13
54						75.69	74.55	73.41	72.27	71.12	69.98	68.84	67.70			65.42	64.27
56						78.83	77.69	76.55	75.41	74.27	73.12	71.98	70.84			68.56	67.42
58							80.83	79.69	78.55	77.41	76.27	75.12	73.98			71.71	70.56
60									81.69	80.55	79.41	78.27	77.12			74.84	73.70
62										84.83	83.69	82.55	81.41	80.27		77.98	76.84
64												85.69	84.55	83.41		81.12	79.98
66														86.55		84.27	83.12
68																87.41	86.27
70																90.55	89.41
72																	92.55

Oval Duct **INSTALLATION**

TAMBE METAL PRODUCTS

Single wall slip fit

1. The fittings are male sized to slip into the pipe section. A good tight fit is necessary for minimalizing friction loss and good sealing. Care should be taken during handling to avoid any dents or distortions that can cause improper fit and difficult installation.
2. A sharp blow to the top of the collar with hand or sheet metal mallet can cause the collar to seat into the duct. For larger sized duct, straddle the duct and slightly compress duct sideways while another person jiggles the fitting into the duct.
3. As a last resort, a half moon cut on the top of the collar to eliminate the “high-spot” and the fitting slips easily into place.

Double wall slip fit

The inner and outer collars of fittings are male sized and designed to slip into the connecting duct. The inner collar projects beyond the outer collar permitting the inner collar to be started into the inner liner of the duct section similar to the single wall technique.

1. Bring bottom of inner collar into the duct section at a slight angle.
2. Using slight pressure, work the rest of the collar into the duct.
3. When the inner collar is fully started into the duct, start the outer collar in the same manner. Tilt the bottom edge slightly upon insertion and tap the “high-spots” to work the collar into the duct.

It is suggested to save time, sub-assemblies be made on the floor then hoisted into place.

Additional suggestions for installation

1. Rest your duct on two blocks of wood and then using your hands and moving the duct, in an up and down motion, will help you make your connection without damaging the duct.
2. Allowances have already been made in fittings for installation. Should a kink occur through handling, by carefully straightening out the kinks and bends a good connection can still be made.
3. **DO NOT** use a hammer and screwdriver to make a connection. The possibility of causing damages internally is a real danger to friction loss. Apply pressure with the heel of your hand or a good thump with your fist can help the fitting slip into the duct.
4. Apply duct sealant to the internal end of the spiral approximately 1” and apply duct sealant around the slip part of your fitting. As the fitting slips into the spiral duct the sealant will not scrape off in the slip connection.
5. Whenever possible brush your internal joint to make it smooth inside and out; also, inspect your sealed joints for coverage. One to two days after completing the connections check connections for shrinkage of the duct sealant. Reapply sealant where needed.

Oval Duct **REINFORCEMENT**

TAMBE METAL PRODUCTS

Double trapeze reinforcement and hanger for oval duct

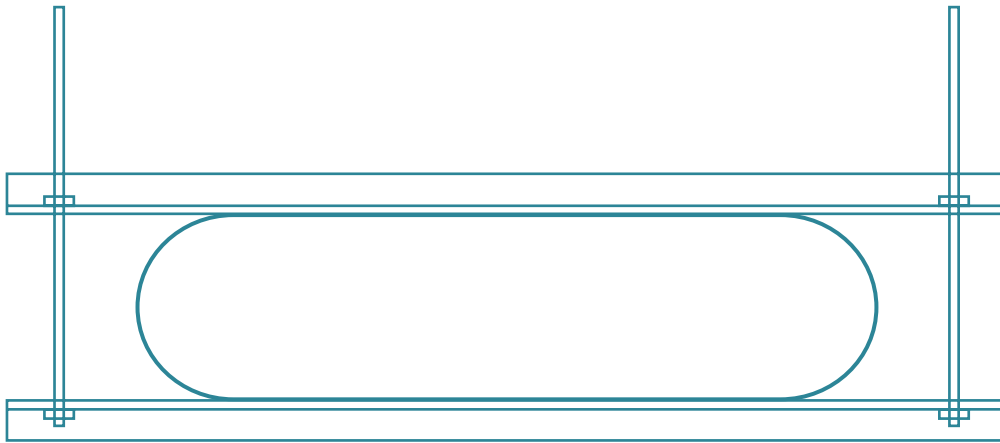

Flat span reinforcement with internal tie rods for oval duct

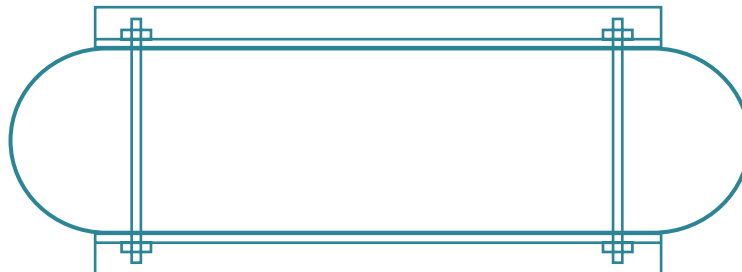

See the following 4 pages for size and spacing of reinforcement.
Reinforcement schedules are shown for 2", 3', 4', and 6" W.G. systems.

Oval Duct **REINFORCEMENT**

TAMBE METAL PRODUCTS

2" W.G. Reinforcement

To use this table:

1. Find the minor axis of the oval size you wish to reinforce in the first row.
2. Go down the column for that minor axis until you reach the major axis of the oval size you wish to reinforce.
3. To the left of the major axis you will find the appropriate reinforcement.

INITIAL SPIRAL SIZE	MINOR AXIS																MAJOR AXIS
	6	8	10	12	14	16	18	20	22	24	26	28	30	32	34	36	
15	B8/20	NR/19	NR/18	NR/17	NR/16												
16	C8/22	B8/21	NR/19	NR/18	NR/17												
17	C8/23	B8/22	NR/21	NR/20	NR/19	NR/18											
18	C6/25	C8/24	B8/23	NR/21	NR/20	NR/19											
19	C8/26	C10/25	B8/24	NR/23	NR/22	NR/21											
20	D8/28	C8/27	C10/26	D8/25	NR/23	NR/22	NR/21										
22	E8/31	D8/30	C8/29	C10/28	NR/27	NR/25	NR/24										
24	E6/34	E8/33	D8/32	C8/31	C10/30	NR/29	NR/27	NR/26									
26	F5/37	E6/36	E8/35	D8/34	C8/33	C10/32	NR/31	NR/29	NR/28								
28	F5/41	F5/39	E6/38	E8/37	D8/36	C8/35	C10/34	NR/33	NR/31	NR/30							
30	F4/44	F5/43	F5/41	E6/40	E8/39	D8/38	C8/37	C10/36	NR/35	NR/33	NR/32						
32	F4/47	F4/46	F5/45	F5/43	E6/42	E8/41	D8/40	C8/39	C10/38	NR/37	NR/35	NR/34					
34	H5/50	F4/49	F4/48	F5/47	F5/45	E6/44	E8/43	D8/42	C8/41	C10/40	NR/39	NR/37	NR/36				
36	H5/53	H5/52	G5/51	G5/50	F5/49	F5/47	E6/46	E8/45	D8/44	C8/43	C10/42	NR/41	NR/39	NR/38			
38	H4/56	H5/55	H5/54	G5/53	G5/52	F6/51	F6/49	E6/48	E8/47	D8/46	C8/45	C10/44	NR/43	NR/41	NR/40		
40	H4/59	H4/58	H5/57	H5/56	G5/55	GS/54	F6/53	F6/51	E8/50	E10/49	D8/48	C8/47	C10/46	NR/45	NR/43	NR/42	
42	G3/63	H4/61	H4/60	H5/59	H5/58	GS/57	G5/56	F6/55	F6/53	E8/52	E10/51	D10/50	C8/49	C10/48	NR/47	NR/45	
44	G3/66	G3/65	H4/63	H4/62	H5/61	H5/60	G5/59	G5/58	F6/57	F6/55	E8/54	E10/53	D10/52	C10/51	NR/50	NR/49	
46	H3/69	G3/68	G3/67	H4/65	H4/64	H5/63	H5/62	G5/61	G5/60	F6/59	F6/57	E8/56	E10/55	D10/54	C10/53	NR/52	
48	I4/72	H3/71	G3/70	G3/69	H4/67	H4/66	H5/65	H5/64	G5/63	G5/62	F6/61	F6/59	E8/58	E10/57	D10/56	C10/55	
50		I4/74	I4/73	I5/72	G3/71	H4/69	H4/68	H5/67	H5/66	G5/65	G5/64	F6/63	F6/61	E8/60	E10/59	D10/58	
52				I5/75	I5/74	I5/73	H5/71	H4/70	H5/69	H5/68	G5/67	G5/66	F6/65	F6/63	E8/62	E10/61	
54						I5/76	I5/75	H5/73	H5/72	H5/71	H5/70	G5/69	G5/68	F6/67	F6/65	E8/64	
56						I5/79	I5/78	I5/77	H5/75	H5/74	H5/73	H6/72	G5/71	G5/70	F6/69	F6/67	
58							I4/81	I5/80	I5/79	H5/77	H5/76	H5/75	H6/74	G6/73	G6/72	F6/71	
60									I5/82	I5/81	H5/79	H5/78	H5/77	H6/76	G6/75	G6/74	
62									I4/85	I5/84	I5/83	H5/81	H5/80	H5/79	H6/78	G6/77	
64											I5/86	I5/85	H5/83	H5/82	H5/81	H6/80	
66													I5/87	H5/85	H5/84	H5/83	
68														I5/89	H5/87	H5/86	
70															I5/91	H5/89	
72																I5/93	

Oval Duct REINFORCEMENT

TAMBE METAL PRODUCTS

3" W.G. Reinforcement

To use this table:

1. Find the minor axis of the oval size you wish to reinforce in the first row.
2. Go down the column for that minor axis until you reach the major axis of the oval size you wish to reinforce.
3. To the left of the major axis you will find the appropriate reinforcement.

INITIAL SPIRAL SIZE	MINOR AXIS																MAJOR AXIS
	6	8	10	12	14	16	18	20	22	24	26	28	30	32	34	36	
15	B8/20	NR/19	NR/18	NR/17	NR/16												
16	C6/22	B8/21	NR/19	NR/18	NR/17												
17	C6/23	B8/22	NR/21	NR/20	NR/19	NR/18											
18	D6/25	C6/24	B8/23	NR/21	NR/20	NR/19											
19	D6/26	D8/25	B8/24	NR/23	NR/22	NR/21											
20	E6/28	D6/27	C8/26	B8/25	NR/23	NR/22	NR/21										
22	E6/31	E6/30	D6/29	C8/28	C8/27	NR/25	NR/24										
24	F5/34	E6/33	E6/32	D6/31	C8/30	C8/29	NR/27	NR/26									
26	F4/37	F5/36	E6/35	E6/34	D6/33	C8/32	C8/31	NR/29	NR/28								
28	F4/41	F4/39	F5/38	E6/37	E6/36	D6/35	C8/34	C8/33	NR/31	NR/30							
30	G4/44	F4/43	F4/41	F5/40	E6/39	E6/38	D6/37	C8/36	C8/35	NR/33	NR/32						
32	G4/47	G4/46	F4/45	F4/43	F5/42	E6/41	E6/40	D8/39	C8/38	C8/37	NR/35	NR/34					
34	H4/50	G4/49	G4/48	F4/47	F4/45	F5/44	E6/43	E6/42	D6/41	C8/40	C8/39	NR/37	NR/36				
36	H4/53	H4/52	H5/51	H5/50	F4/49	F4/47	F5/46	E6/45	E6/44	D6/43	C8/42	C8/41	NR/39	NR/38			
38	H3/56	H4/55	H4/54	H5/53	H5/52	G5/51	G5/49	F5/48	E6/47	E6/46	D6/45	C8/44	C8/43	NR/41	NR/40		
40	H3/59	H3/58	H4/57	H4/56	H5/55	H5/54	G5/53	G5/51	F6/50	E6/49	E6/48	D6/47	C8/46	C8/45	NR/43	NR/42	
42	H3/63	H3/61	H3/60	H4/59	H4/58	H5/57	H5/56	G5/55	G5/53	F6/52	E6/51	E8/50	D6/49	C8/48	C8/47	NR/45	
44	H3/66	H3/65	H3/63	H3/62	H4/61	H4/60	H5/59	H5/58	G5/57	G5/55	F6/54	E6/53	E8/52	D8/51	C8/50	C8/49	
46	I3/69	H3/68	H3/67	H3/65	H3/63	H4/63	H4/62	H5/61	H5/60	G5/59	G5/57	F6/56	E6/55	E8/54	D8/53	C8/52	
48	I3/72	I3/71	H3/70	H3/69	H3/67	H3/66	H4/65	H4/64	H5/63	H5/62	G5/61	G5/59	F6/58	E6/57	E8/56	D8/55	
50		I4/74	I3/73	I4/72	H3/71	H3/69	H3/68	H4/67	H4/66	H5/65	H5/64	G5/63	G5/61	F6/60	E6/59	E8/58	
52				I4/75	I4/74	I4/73	I5/71	H3/70	H4/69	H4/68	H5/67	H5/66	G5/65	G5/63	F6/62	E6/61	
54						I4/76	I4/75	I5/73	I5/72	I5/71	H4/70	H5/69	H5/68	G5/67	G5/65	F6/64	
56						I3/79	I4/78	I4/77	I5/75	I5/74	I5/73	I5/72	H5/71	H5/70	G5/69	G5/67	
58							I3/81	I4/80	I4/79	I5/77	I5/76	I5/75	I5/74	H6/73	H6/72	G5/71	
60									I4/82	I4/81	I5/79	I5/78	I5/77	I5/76	H6/75	H6/74	
62									I3/85	I4/84	I4/83	I5/81	I5/80	I5/79	I5/78	H6/77	
64											I4/86	I4/85	I5/83	I5/82	I5/81	I5/80	
66													I4/87	I5/85	I5/84	I5/83	
68														I4/89	I5/87	I5/86	
70															I4/91	I5/89	
72																I4/93	

Oval Duct REINFORCEMENT

TAMBE METAL PRODUCTS

4" W.G. Reinforcement

To use this table:

1. Find the minor axis of the oval size you wish to reinforce in the first row.
2. Go down the column for that minor axis until you reach the major axis of the oval size you wish to reinforce.
3. To the left of the major axis you will find the appropriate reinforcement.

INITIAL SPIRAL SIZE	MINOR AXIS																MAJOR AXIS
	6	8	10	12	14	16	18	20	22	24	26	28	30	32	34	36	
15	C5/20	C6/19	NR/18	NR/17	NR/16												
16	C5/22	C5/21	B6/19	NR/18	NR/17												
17	D5/23	C5/22	C6/21	NR/20	NR/19	NR/18											
18	E5/25	C5/24	C5/23	B6/21	NR/20	NR/19											
19	E6/26	D6/25	C5/24	C6/23	NR/22	NR/21											
20	E5/28	E6/27	D6/26	C5/25	B6/23	NR/22	NR/21										
22	F5/31	E5/30	E6/29	D6/28	B8/27	NR/25	NR/24										
24	F5/34	F5/33	E5/32	E6/31	D6/30	B8/29	NR/27	NR/26									
26	G4/37	F5/36	F5/35	E5/34	E6/33	D6/32	B8/31	NR/29	NR/28								
28	G4/41	G4/39	F5/38	F5/37	E5/36	E6/35	D6/34	B8/33	NR/31	NR/30							
30	G3/44	G4/43	G4/41	F5/40	F5/39	E5/38	E6/37	D6/36	B8/35	NR/33	NR/32						
32	G3/47	G3/46	G4/45	G4/43	F5/42	F5/41	E5/40	E6/39	D6/38	B8/37	NR/35	NR/34					
34	H3/50	G3/49	G3/48	G4/47	G4/45	F5/44	F5/43	E5/42	E6/41	D6/40	B8/39	NR/37	NR/36				
36	H3/53	H3/52	H4/51	H4/50	G4/49	G4/47	F5/46	F5/45	E5/44	E6/43	D6/42	B8/41	NR/39	NR/38			
38	I3/56	H3/55	H3/54	H4/53	H4/52	H5/51	H5/49	F5/48	F5/47	E5/46	E6/45	D6/44	B8/43	NR/41	NR/40		
40	I3/59	I3/58	H3/57	H3/56	H4/55	H4/54	H5/53	H5/51	G6/50	F6/49	E5/48	E6/47	D6/46	B8/45	NR/43	NR/42	
42	I3/63	I3/61	I3/60	H3/59	H3/58	H4/57	H4/56	H5/55	H5/53	G6/52	F6/51	E6/50	E6/49	D6/48	B8/47	NR/45	
44	I3/66	I3/65	I3/63	I3/62	H3/61	H3/60	H4/59	H4/58	H5/57	H5/55	G6/54	F6/53	E6/52	E8/51	D8/50	B8/49	
46		I3/68	I3/67	I3/65	I3/64	H3/63	H3/62	H4/61	H4/60	H5/59	H5/57	G6/56	F6/55	E6/54	E8/53	D8/52	
48		I2.5/71	I3/70	I3/69	I3/67	I3/66	H3/65	H3/64	H4/63	H4/62	H5/61	H5/59	G6/58	F6/57	E6/56	E8/55	
50		J3/74	J3/73	H3/72	I3/71	I3/69	I3/68	H3/67	H3/66	H4/65	H4/64	H5/63	H5/61	G6/60	F6/59	E6/58	
52				H3/75	H3/74	H3/73	I4/71	I3/70	H3/69	H3/68	H4/67	H4/66	H5/65	H5/63	G6/62	F6/61	
54						H3/76	H3/75	I4/73	I4/72	I5/71	H3/70	H4/69	H4/68	H5/67	H5/65	G6/64	
56						J3/79	H3/78	H3/77	I4/75	I4/74	I5/73	I5/72	H4/71	H4/70	H5/69	H5/67	
58							J3/81	H3/80	H3/79	I4/77	I4/76	I5/75	I5/74	I5/73	I5/72	H5/71	
60									H3/82	H3/81	I4/79	I4/78	I5/77	I5/76	I5/75	I5/74	
62									J3/85	H3/84	H3/83	I4/81	I4/80	I5/79	I5/78	I5/77	
64											H3/86	H3/85	I4/83	I4/82	I5/81	I5/80	
66													H3/87	I4/85	I4/84	I5/83	
68														H3/89	I4/87	I4/86	
70															H3/91	I4/89	
72																H3/93	

Oval Duct REINFORCEMENT

TAMBE METAL PRODUCTS

6" W.G. Reinforcement

To use this table:

1. Find the minor axis of the oval size you wish to reinforce in the first row.
2. Go down the column for that minor axis until you reach the major axis of the oval size you wish to reinforce.
3. To the left of the major axis you will find the appropriate reinforcement.

INITIAL SPIRAL SIZE	MINOR AXIS																MAJOR AXIS
	6	8	10	12	14	16	18	20	22	24	26	28	30	32	34	36	
15	C4/20	C5/19	NR/18	NR/17	NR/16												
16	D4/22	C4/21	C5/19	NR/18	NR/17												
17	E4/23	C4/22	C5/21	NR/20	NR/19	NR/18											
18	E4/25	D4/24	C4/23	C5/21	NR/20	NR/19											
19	E5/26	E5/25	C4/24	C5/23	NR/22	NR/21											
20	F5/28	E5/27	D5/26	C4/25	C5/23	NR/22	NR/21										
22	F4/31	F5/30	E5/29	D5/28	D5/27	B6/25	NR/24										
24	G4/34	F4/33	F5/32	E5/31	D5/30	D5/29	B6/27	NR/26									
26	H3/37	G4/36	F4/35	E5/34	E5/33	D5/32	D5/31	B6/29	NR/28								
28	H3/41	H3/39	G4/38	F4/37	F5/36	E5/35	D5/34	D5/33	B6/31	NR/30							
30	H2.5/44	H3/43	H3/41	G4/40	F4/39	F5/38	E5/37	D5/36	D5/35	B6/33	NR/32						
32	H2.5/47	H2.5/46	H3/45	H3/43	G4/42	F4/41	F5/40	E5/39	D5/38	D5/37	B6/35	NR/34					
34	I2.5/50	H2.5/48	H2.5/48	H3/47	H3/45	G4/44	F4/43	F5/42	E5/41	D5/40	D5/39	B6/37	NR/36				
36	I2.5/53	I2.5/52	H3/51	H3/50	H3/49	H4/47	G4/46	F4/45	F5/44	E5/43	D5/42	D5/41	B6/39	NR/38			
38	I2.5/56	I2.5/55	I2.5/54	H3/53	H3/52	H4/51	H4/49	G4/48	F4/47	F5/46	E5/45	D5/44	D5/43	B6/41	NR/40		
40	I2.5/59	I2.5/58	I2.5/57	I2.5/56	H3/55	H3/54	H4/53	H4/51	H5/50	G5/49	F5/48	E5/47	D5/46	D5/45	B6/43	NR/42	
42	I2.5/63	I2.5/61	I2.5/60	I2.5/59	I2.5/58	H3/57	H3/56	H4/55	H4/53	H5/52	G5/51	F6/50	E5/49	D5/48	D5/45	B6/45	
44	I2.5/66	I2.5/65	I2.5/63	I2.5/62	I2.5/61	I2.5/60	H3/59	H3/58	H4/57	H4/55	H5/54	G5/53	F6/52	F6/51	D6/50	D5/49	
46	J2/69	I2.5/68	I2.5/67	I2.5/65	I2.5/64	I2.5/63	I2.5/62	H3/61	H3/60	H4/59	H4/57	H5/56	G5/55	F6/54	F6/53	D6/52	
48	J2.5/72	J2/74	I2.5/70	I2.5/69	I2.5/67	I2.5/66	I2.5/65	I2.5/64	H3/63	H3/62	H4/61	H4/59	H5/58	G5/57	F6/56	F6/55	
50		J2.5/74	J2.5/73	J3/72	I2.5/71	I2.5/69	I2.5/68	I2.5/67	I2.5/66	H3/65	H3/64	H4/63	H4/61	H5/60	G5/59	F6/58	
52				J2.5/75	J3/74	J3/73	I3/71	I2.5/70	I2.5/69	I2.5/68	H3/67	H3/66	H4/65	H4/63	H5/62	G5/61	
54						J3/76	J3/75	I3/73	I3/72	I4/71	I2.5/70	H3/69	H3/68	H4/67	H4/65	H5/64	
56						J2.5/79	J3/78	J3/77	I3/75	I3/74	I4/73	I4/72	H3/71	H3/70	H4/69	H4/67	
58							J2.5/81	J3/80	J3/79	I3/77	I3/76	I4/75	I4/74	I4/73	I4/72	H4/71	
60									J3/82	J3/81	I3/79	I3/78	I4/77	I4/76	I4/75	I4/74	
62									J2.5/85	J3/84	J3/83	I3/81	I3/80	I4/79	I4/78	I4/77	
64											J3/86	J3/85	I3/83	I3/82	I4/81	I4/80	
66													J3/87	I3/85	I3/84	I4/83	
68														J3/89	I3/87	I3/86	
70															J3/91	I3/89	
72																J3/93	

Single Wall Oval **ELBOWS**

TAMBE METAL PRODUCTS

HB

HARD BEND

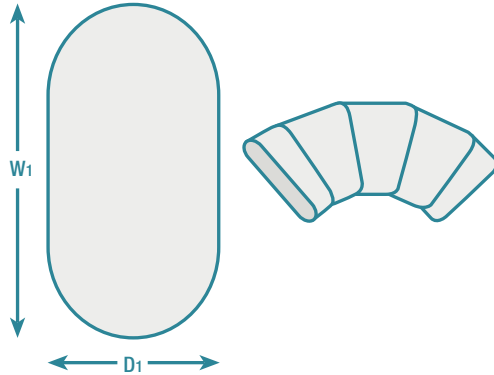

EB

EASY BEND

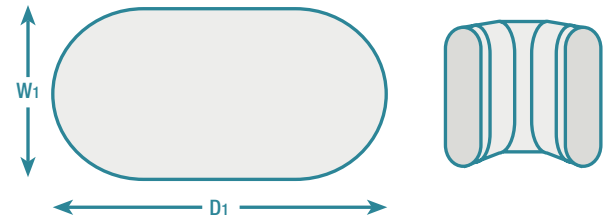

E90

90° 5-PC. ELBOW

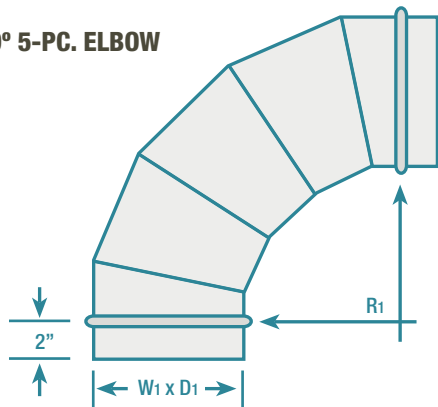

E45

45° 3-PIECE ELBOW

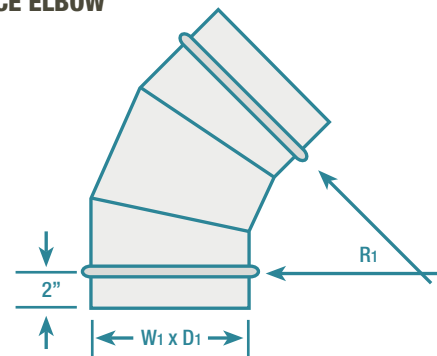

E60

60° 3-PC. ELBOW

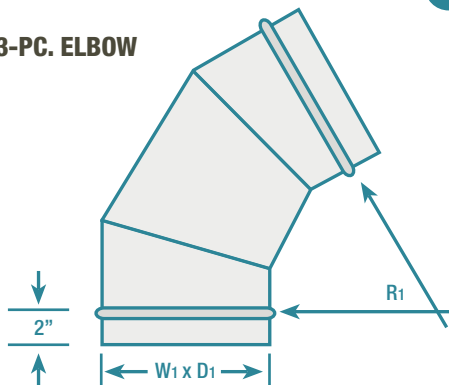

E15/E30

15° & 30° 2-PIECE ELBOW

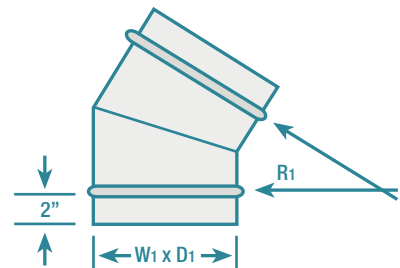

Single Wall Oval **ELBOWS**

TAMBE METAL PRODUCTS

90° 3-PC. ELBOW WITH STRAIGHT LATERAL

E90L

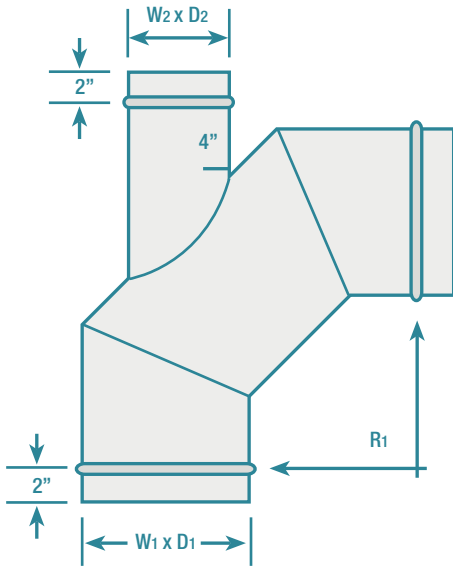

E290/EV290

With or without vanes.

90° 2-PC. ELBOW

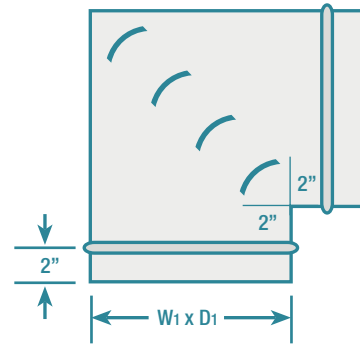

D1	No. of vanes
3-9	2
10-14	3
15-19	4
20-60	5
≥60	Max 12" spacing

45° 2-PC. ELBOW WITH STRAIGHT LATERAL

E45L

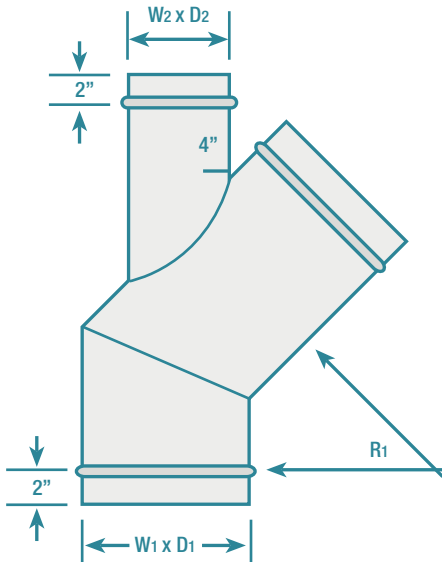

90° 5-PC. ELBOW WITH REDUCER

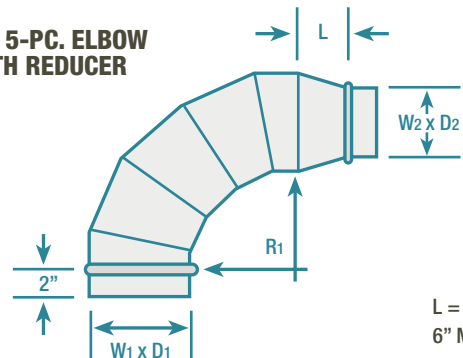

$L = W_1 - W_2$
6" Minimum

45° 3-PC. ELBOW WITH REDUCER

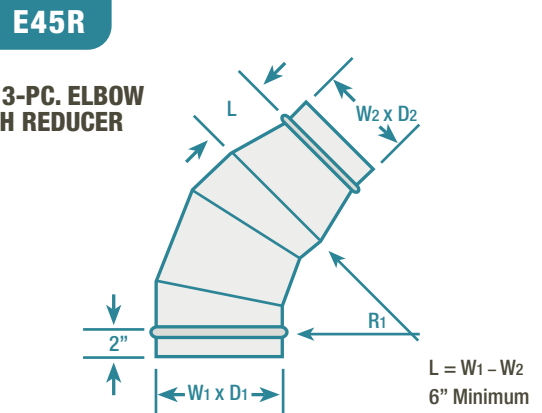

$L = W_1 - W_2$
6" Minimum

Single Wall Oval STRAIGHT TEES

TAMBE METAL PRODUCTS

T

TEE

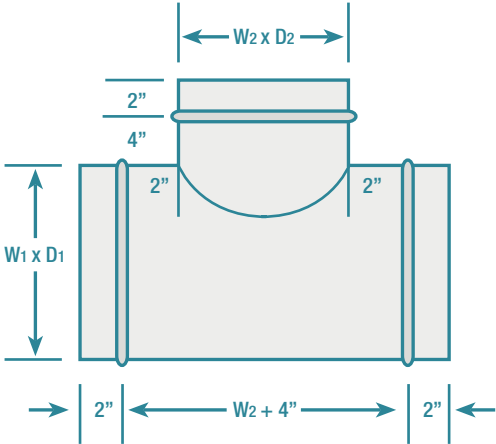

TR

REDUCING TEE

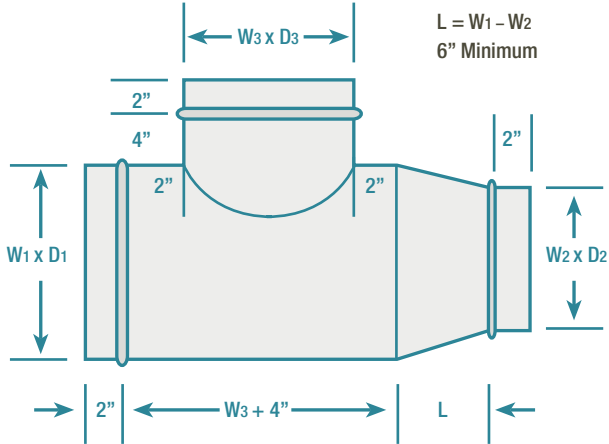

TX

TEE CROSS

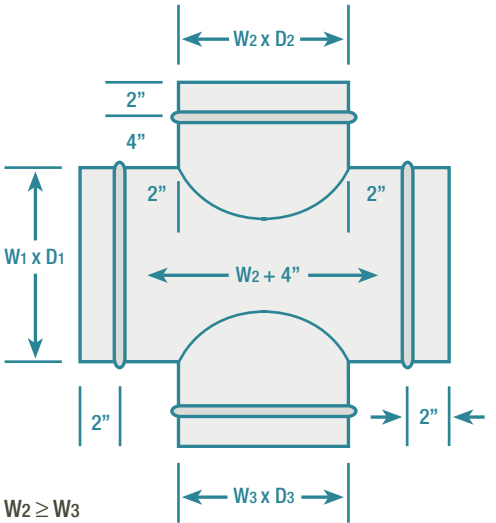

TRX

REDUCING TEE CROSS

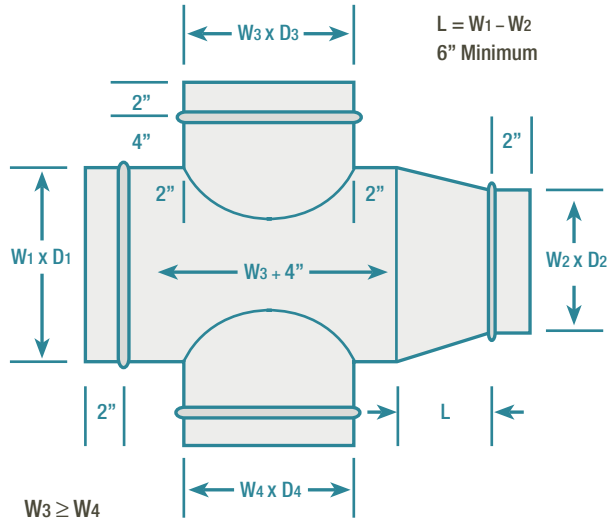

Single Wall Oval CONICAL TEES

TAMBE METAL PRODUCTS

CT

CONICAL TEE

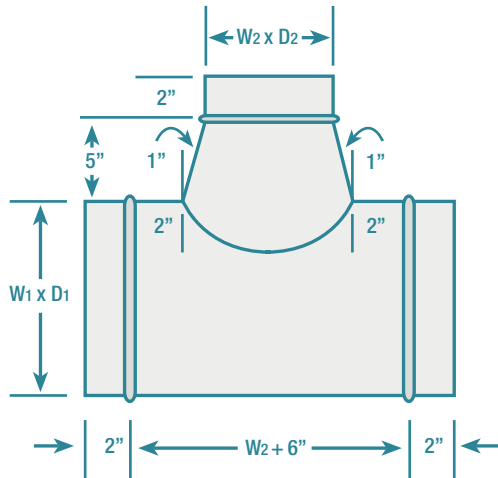

CTR

REDUCING CONICAL TEE

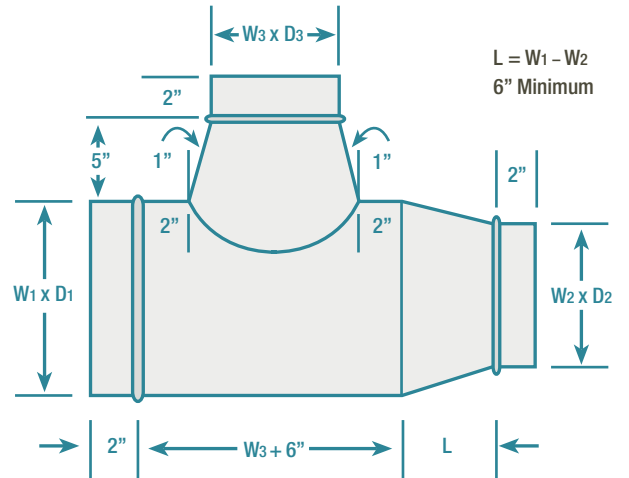

CTX

CONICAL CROSS

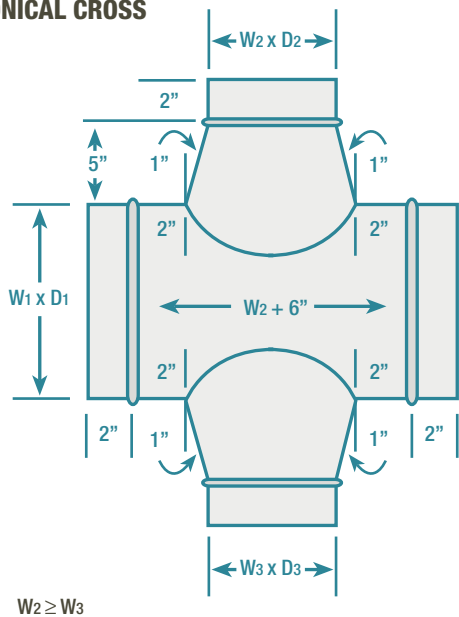

CTRX

REDUCING CONICAL TEE CROSS

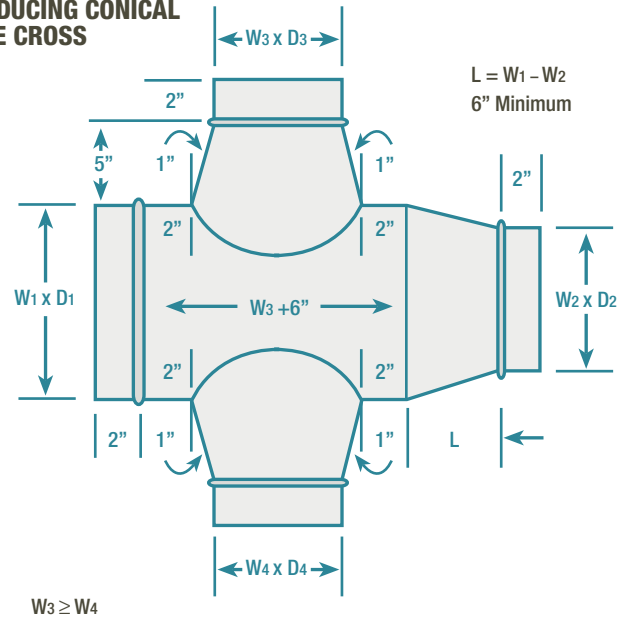

Single Wall Oval **SHOE TEES**

TAMBE METAL PRODUCTS

ST

SHOE TEE

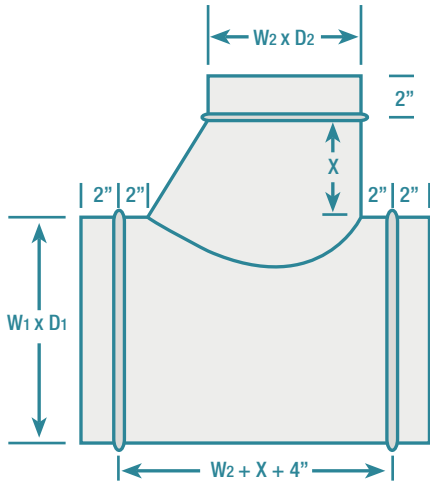

W2	X
3 thru 8	5"
9 thru 16	7"
17 thru 26	10"
27" and up	13"

STR

REDUCING SHOE TEE

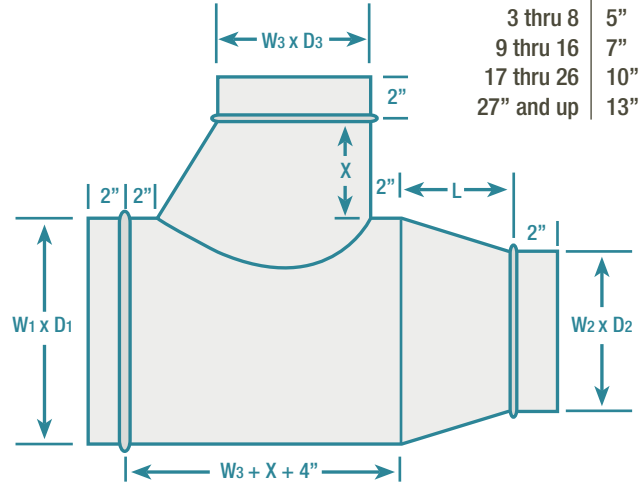

W3	X
3 thru 8	5"
9 thru 16	7"
17 thru 26	10"
27" and up	13"

$L = W1 - W2$
Minimum 6"

STX

SHOE TEE CROSS

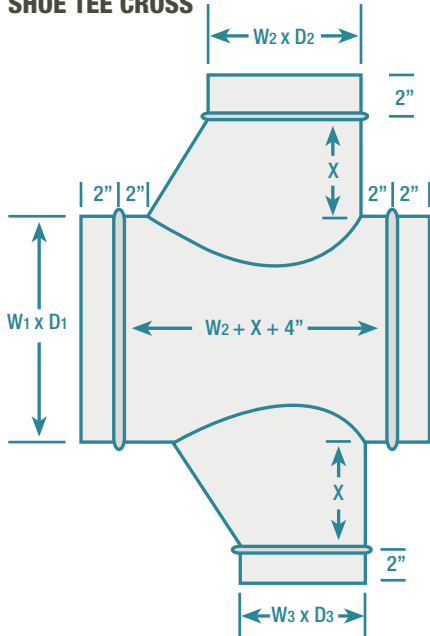

W2, W3	X
3 thru 8	5"
9 thru 16	7"
17 thru 26	10"
27" and up	13"

$W2 \geq W3$

STRX

REDUCING SHOE TEE CROSS

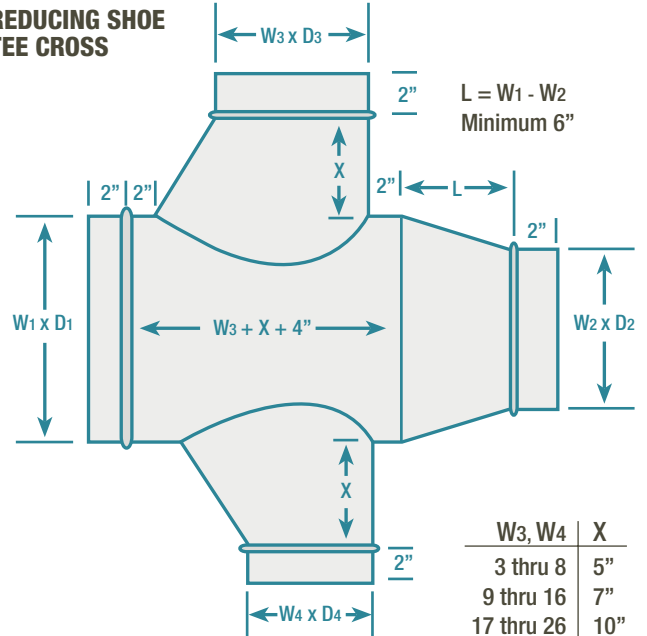

$L = W1 - W2$
Minimum 6"

W3, W4	X
3 thru 8	5"
9 thru 16	7"
17 thru 26	10"
27" and up	13"

$W3 \geq W4$

Single Wall Oval **STRAIGHT LATERALS**

TAMBE METAL PRODUCTS

L

45° LATERAL

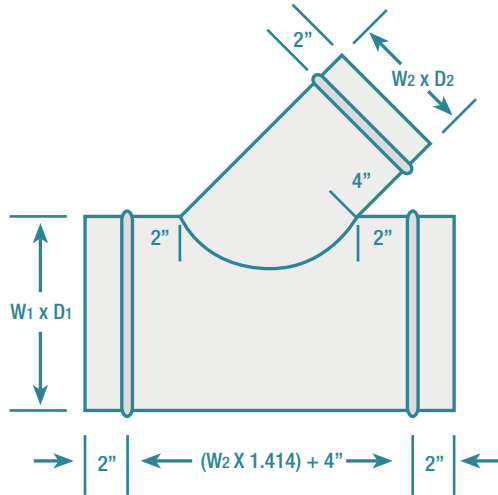

LR

45° REDUCING LATERAL

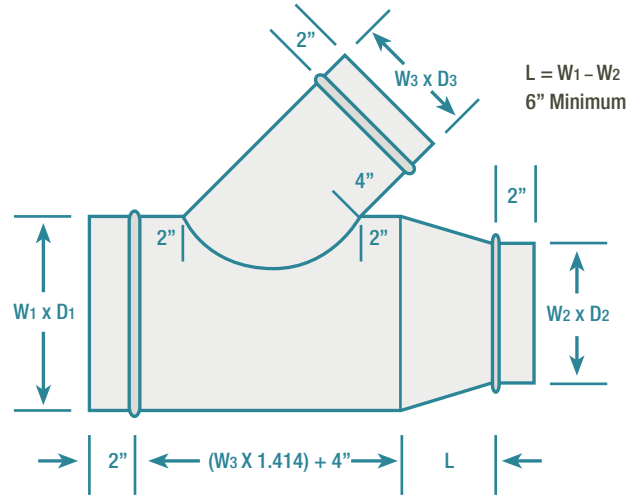

LX

45° LATERAL CROSS

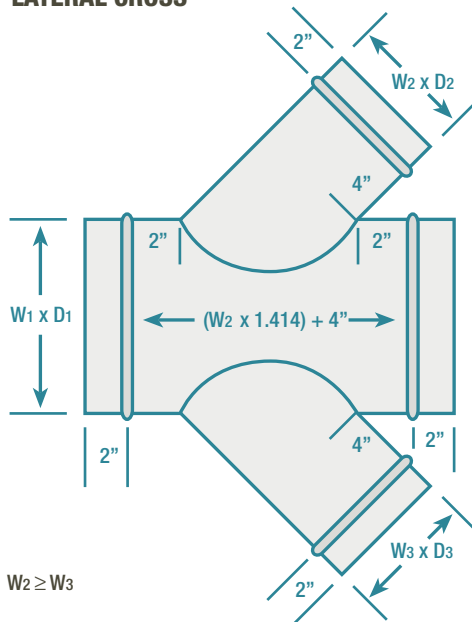

LRX

45° REDUCING LATERAL CROSS

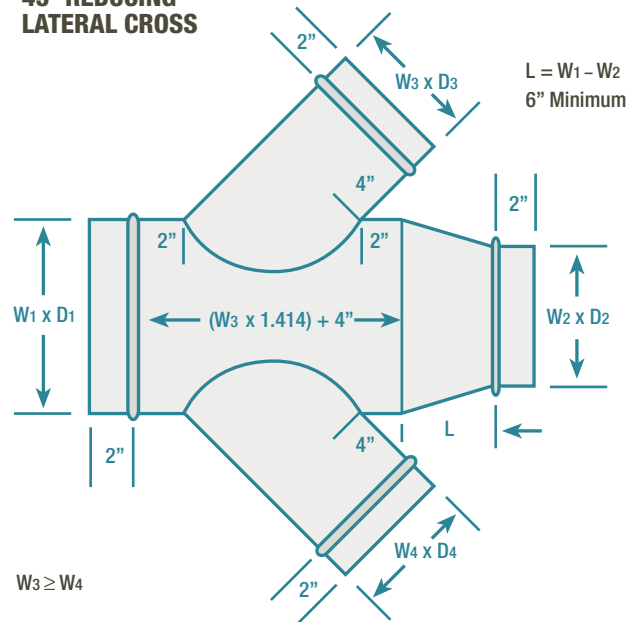

Single Wall Oval CONICAL LATERALS

TAMBE METAL PRODUCTS

CL

45° CONICAL LATERAL

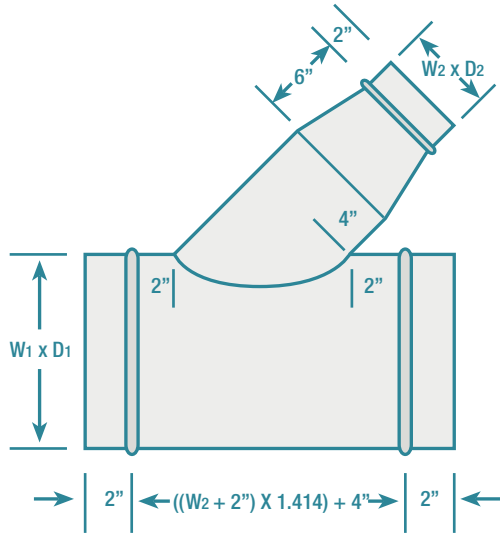

CLR

45° REDUCING CONICAL LATERAL

$L = W_1 - W_2$
6" Minimum

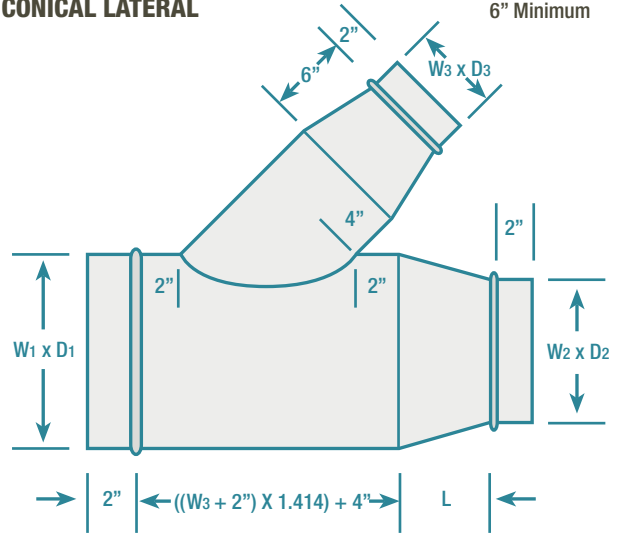

CLX

45° CONICAL LATERAL CROSS

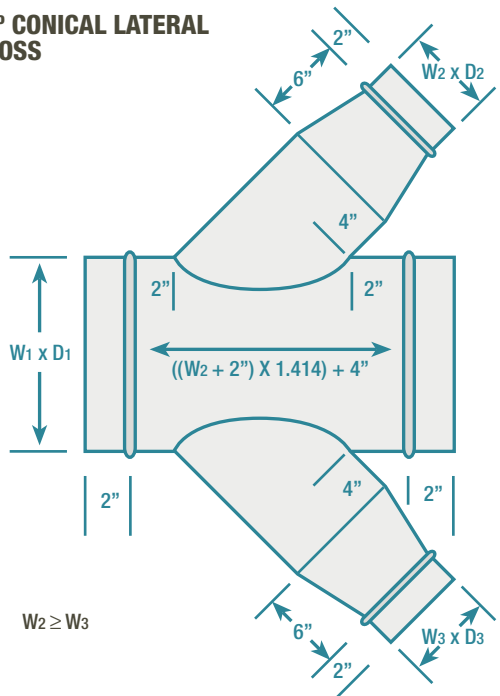

CLR X

45° REDUCING CONICAL LATERAL CROSS

$L = W_1 - W_2$
6" Minimum

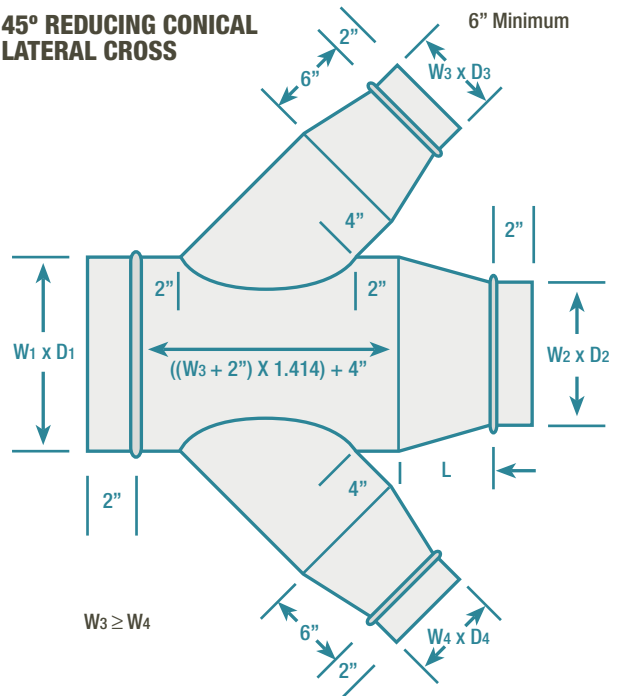

Single Wall Oval MISCELLANEOUS

TAMBE METAL PRODUCTS

RDC

CONCENTRIC REDUCER

$L = W_1 - W_2$
6" Minimum

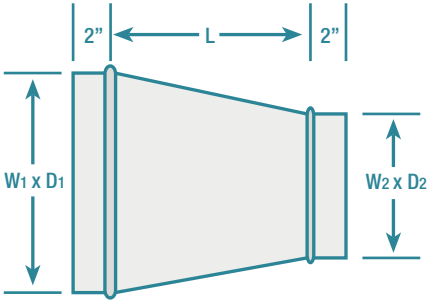

RDE

ECCENTRIC REDUCER

$L = 2 [W_1 - W_2]$
6" Minimum

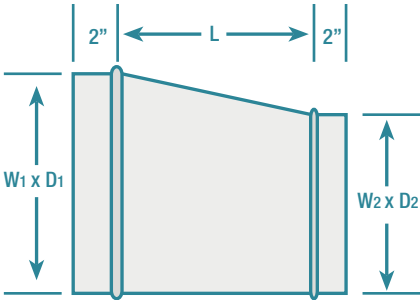

PC

PIPE COUPLING

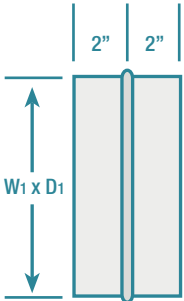

FC

FITTING COUPLING

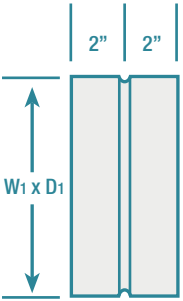

RTR

RECTANGLE TO ROUND

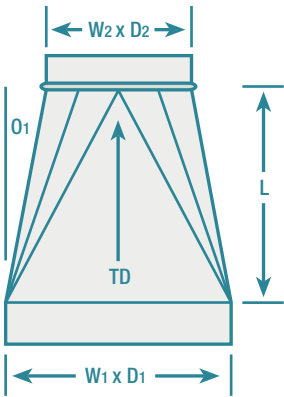

EC

END CAP

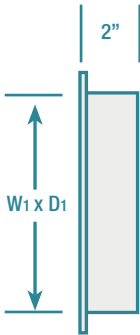

Single Wall Oval MISCELLANEOUS

TAMBE METAL PRODUCTS

SET

OFFSET

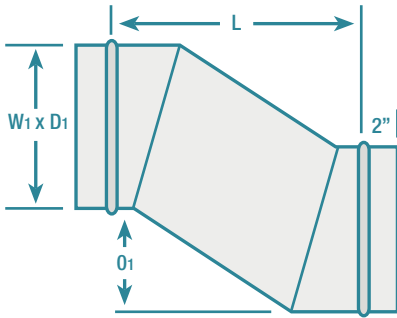

ROET

ROUND TO ROUND

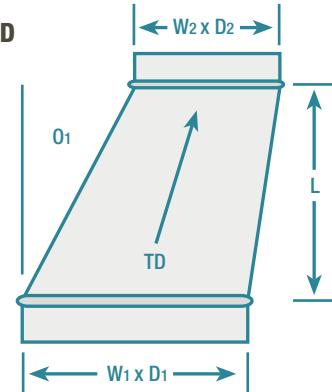

Y45

Y BRANCH

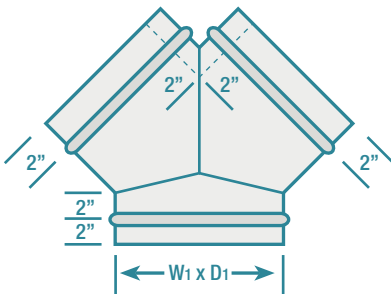

YR45

REDUCING Y BRANCH

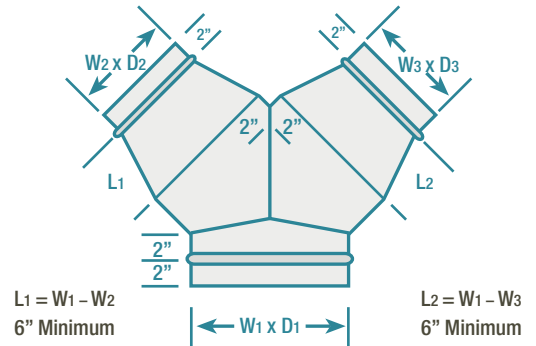

BHT/BHTV

BULL HEAD TEE With or without vanes.

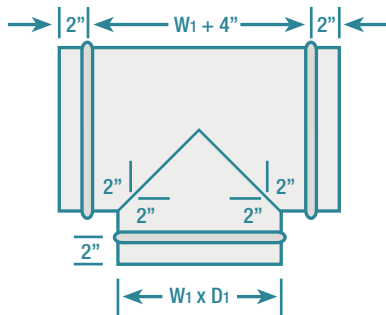

D1	No. of vanes
3-7	1
8-10	3
10-60	5
>60	Max 12" spacing

BHTR/BHTRV

REDUCING BULL HEAD TEE With or without vanes.

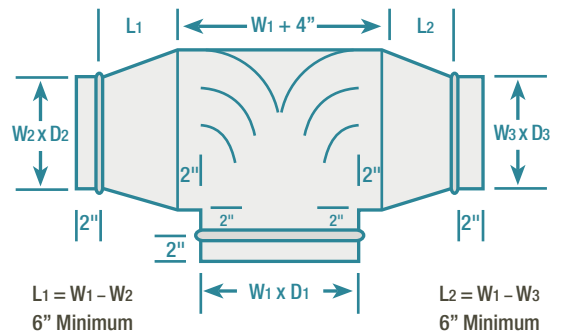

Shop/Field Installed **ACCESSORIES**

TAMBE METAL PRODUCTS

TAP 90

TAP

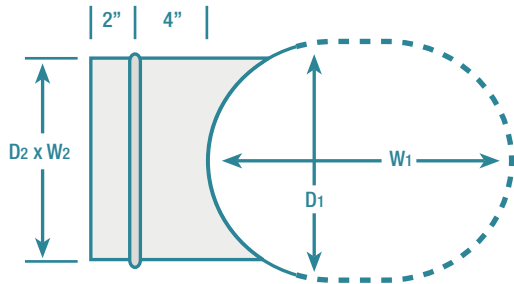

Standard flange is 1/2".
2" saddle is also available.

CTAP 90

CONICAL TAP

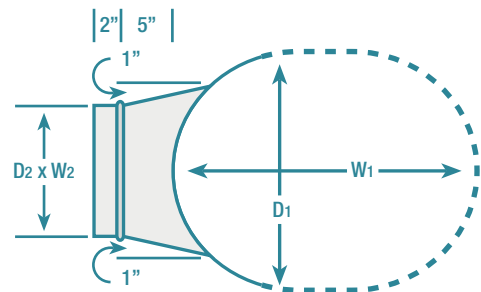

Standard flange is 1/2".
2" saddle is also available.

TAP 45

LATERAL TAP

Standard flange is 1/2". 2" saddle is also available.

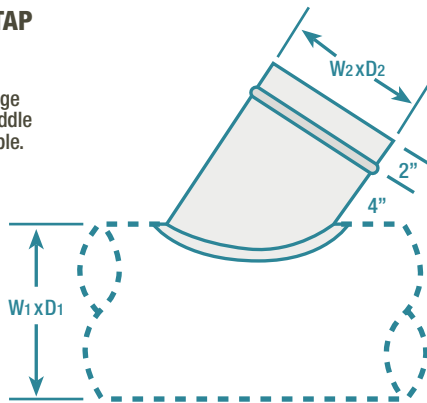

STR

SHOE TAP

W2	L
3 thru 8	5"
9 thru 16	7"
17 thru 26	10"
27" and up	13"

Standard flange is 1/2". 2" saddle is also available.

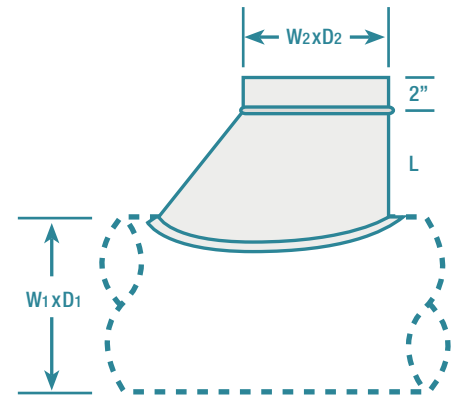

RECTAP

REGISTER TAP

Flange in or out

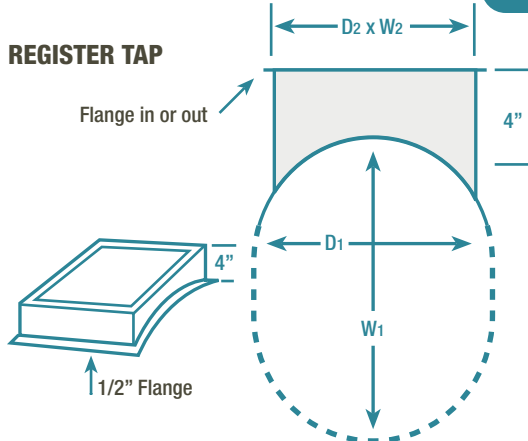

ADOOR

ACCESS DOOR

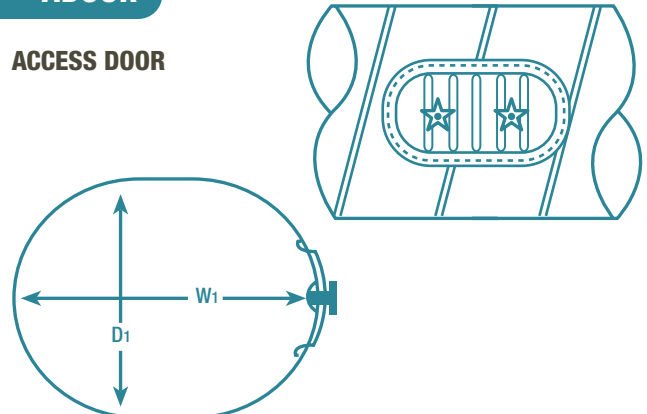

Double Wall Oval **ELBOWS**

TAMBE METAL PRODUCTS

HB

HARD BEND

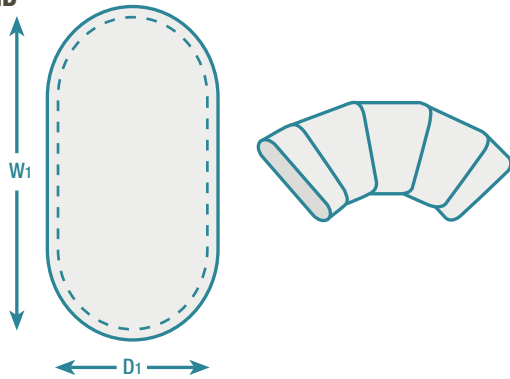

EB

EASY BEND

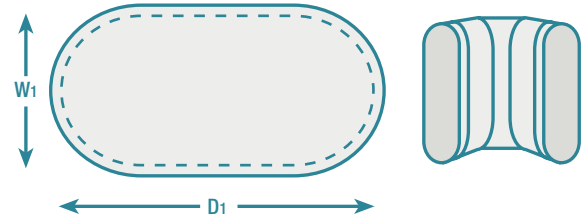

E90

90° 5-PC. ELBOW

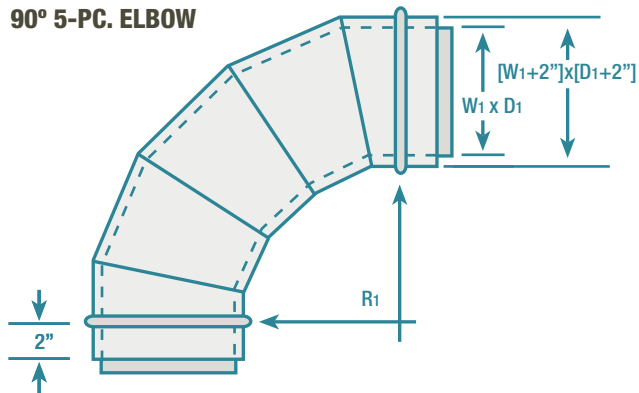

E45

45° 3-PIECE ELBOW

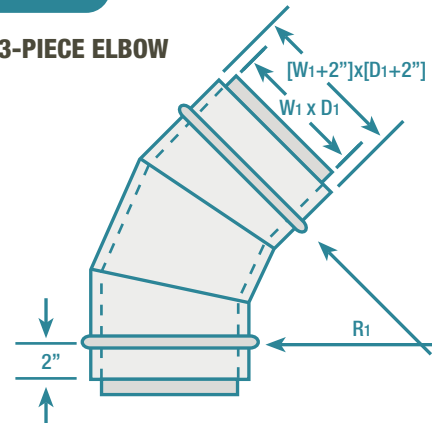

E60

60° 3-PC. ELBOW

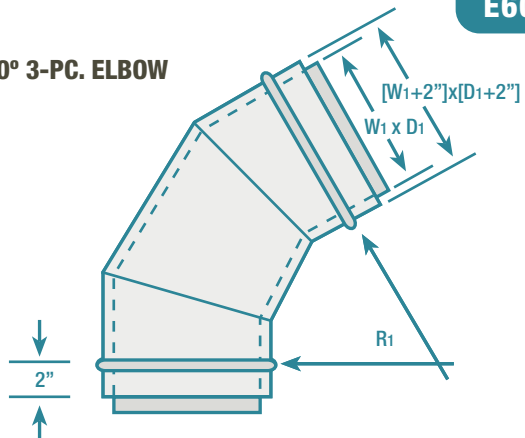

E15/E30

**15° & 30°
2-PIECE ELBOW**

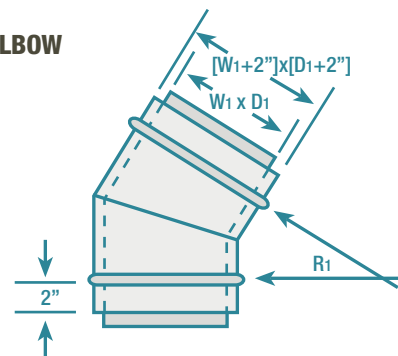

Double Wall Oval **ELBOWS**

TAMBE METAL PRODUCTS

90° 3-PC. ELBOW WITH STRAIGHT LATERALS

E90L

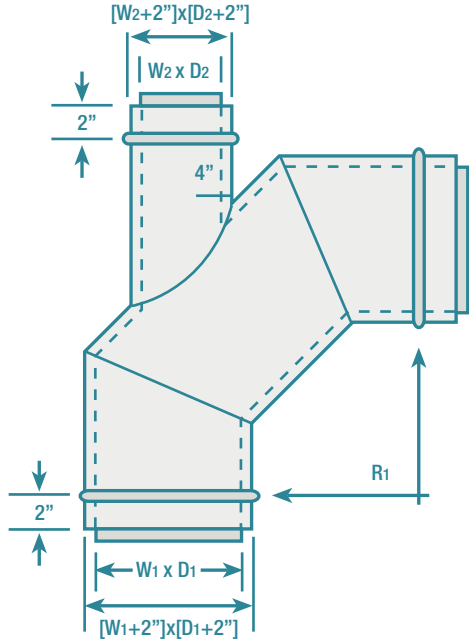

E290/EV290

With or without vanes

90° 2-PC. ELBOW

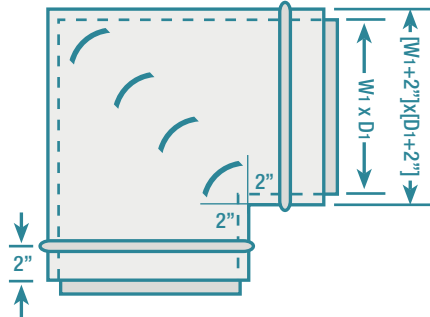

D1	No. of vanes
3-9	2
10-14	3
15-19	4
20-60	5
≥60	Max 12" spacing

E90R

90° 5-PC. ELBOW WITH REDUCER

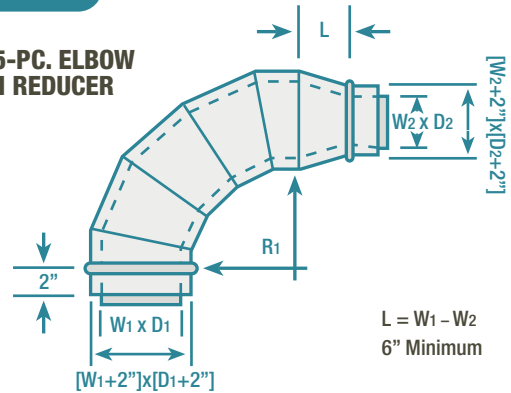

45° 2-PC. ELBOW WITH STRAIGHT LATERAL

E45L

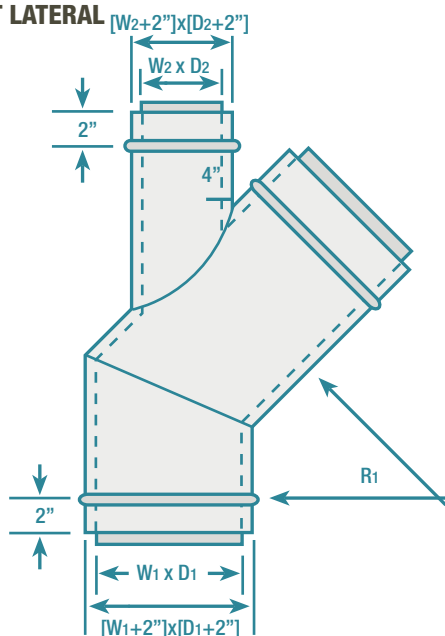

E45R

45° 3-PC. ELBOW WITH REDUCER

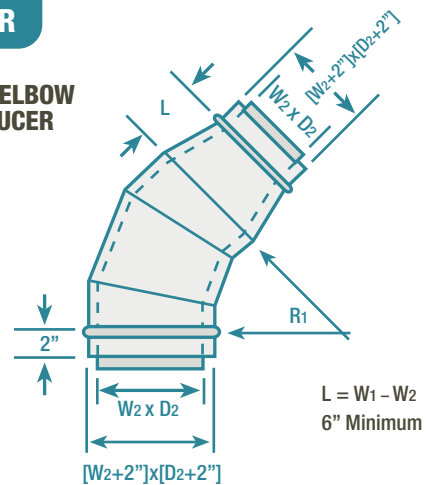

Double Wall Oval STRAIGHT TEES

TAMBE METAL PRODUCTS

T

TEE

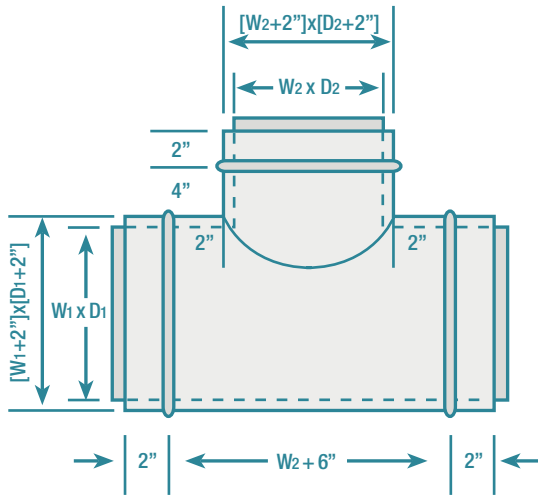

TR

REDUCING TEE

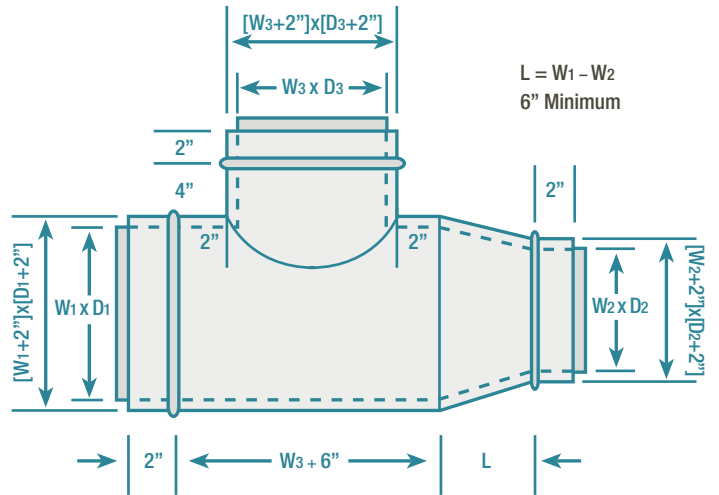

TX

TEE CROSS

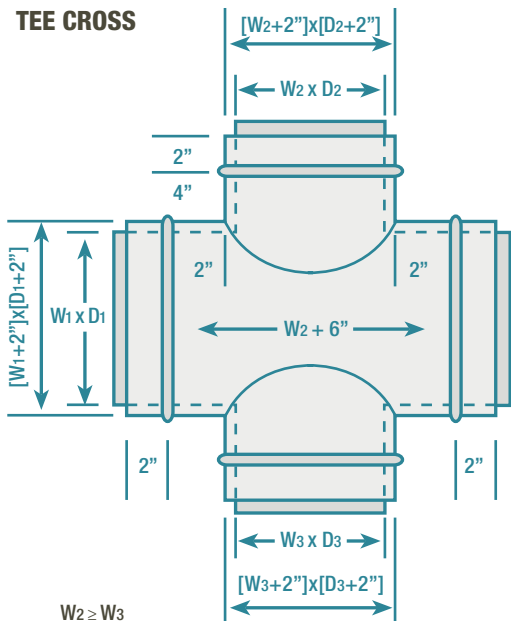

TRX

REDUCING TEE CROSS

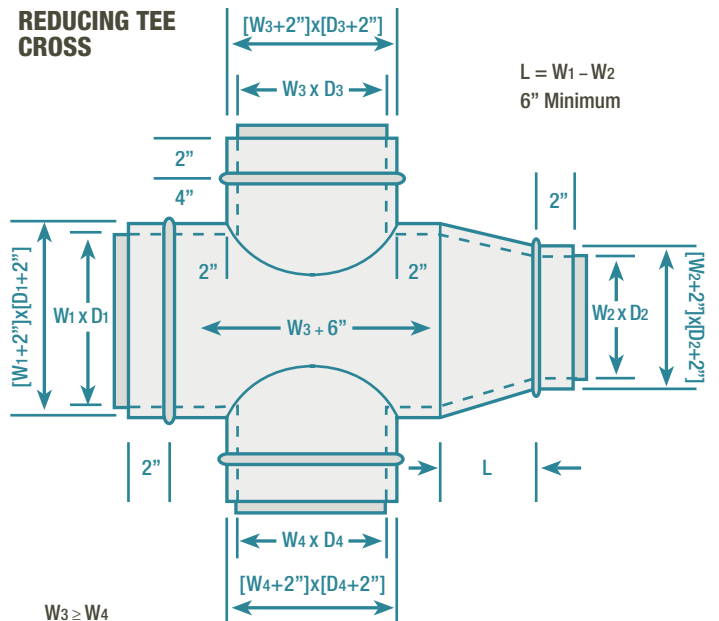

Double Wall Oval CONICAL TEES

TAMBE METAL PRODUCTS

CT

CONICAL TEE

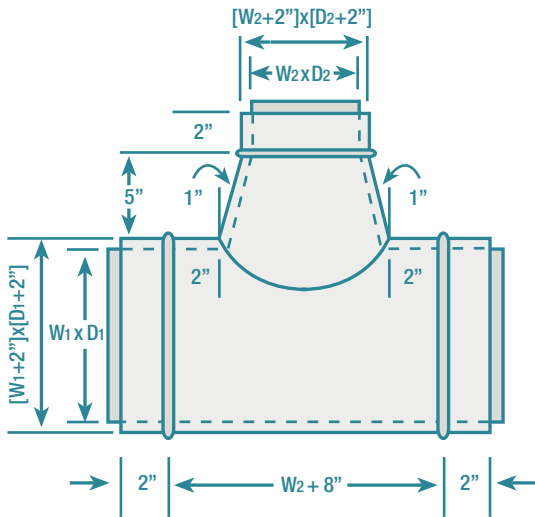

CTR

REDUCING CONICAL TEE

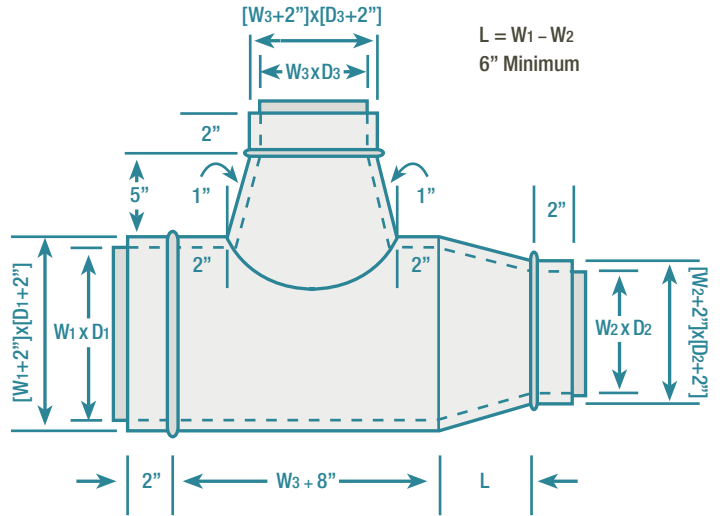

CTX

CONICAL CROSS

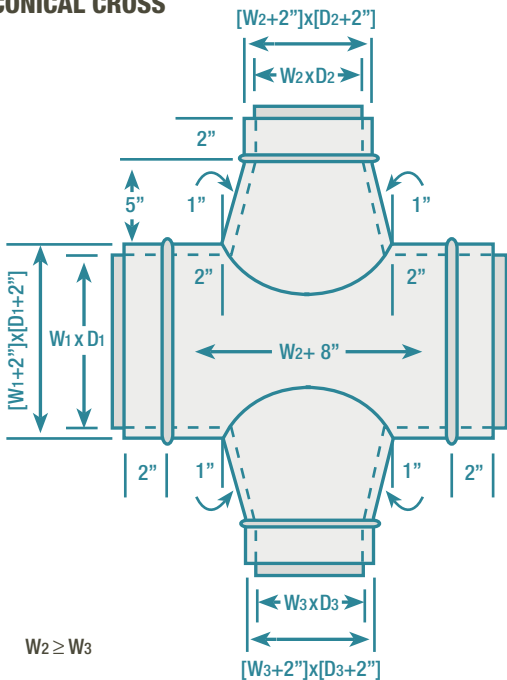

CTRX

REDUCING CONICAL CROSS

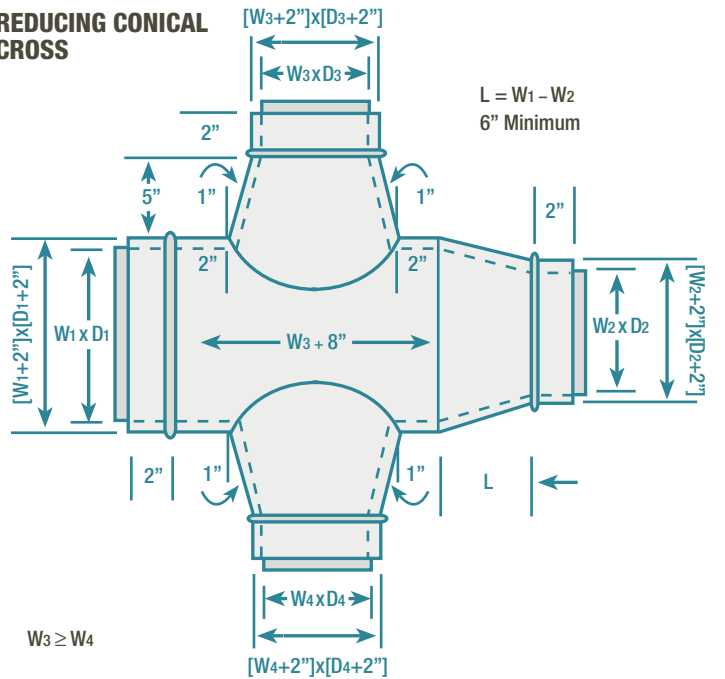

Double Wall Oval SHOE TEES

TAMBE METAL PRODUCTS

SHOE TEE

ST

W ₂	X
3 thru 8	5"
9 thru 16	7"
17 thru 26	10"
27" and up	13"

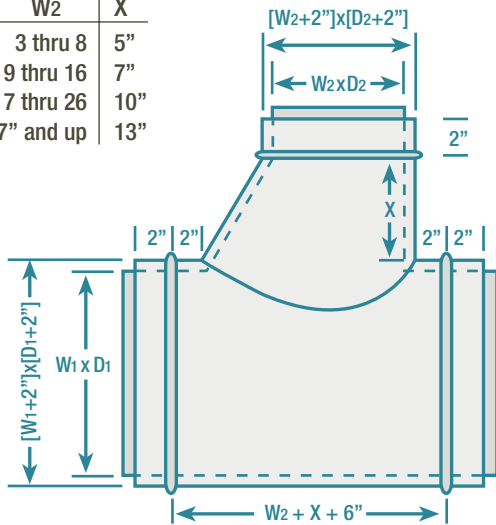

STR

REDUCING SHOE TEE

W ₃	X
3 thru 8	5"
9 thru 16	7"
17 thru 26	10"
27" and up	13"

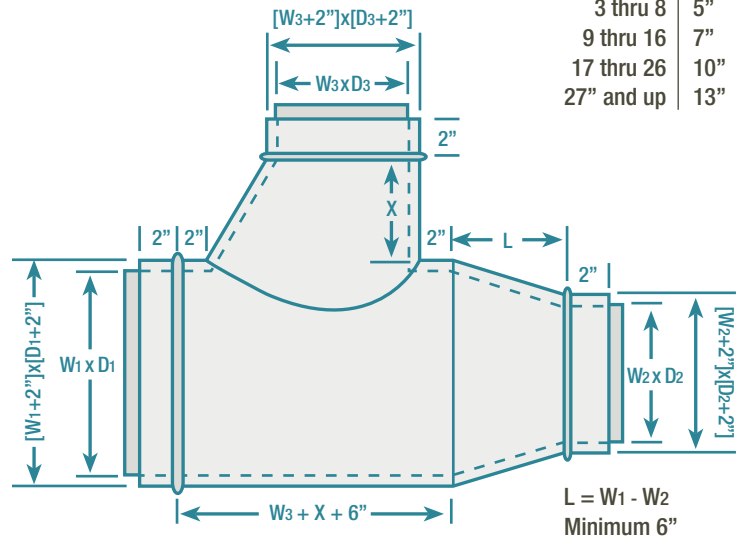

L = W₁ - W₂
Minimum 6"

SHOE TEE CROSS

STX

W ₂ , W ₃	X
3 thru 8	5"
9 thru 16	7"
17 thru 26	10"
27" and up	13"

W₂ ≥ W₃

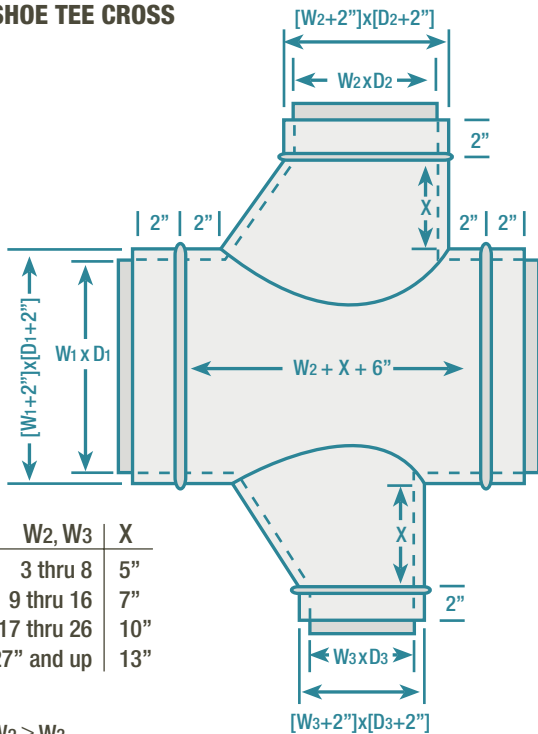

STRX

REDUCING SHOE TEE CROSS

L = W₁ - W₂
Minimum 6"

W₃ ≥ W₄

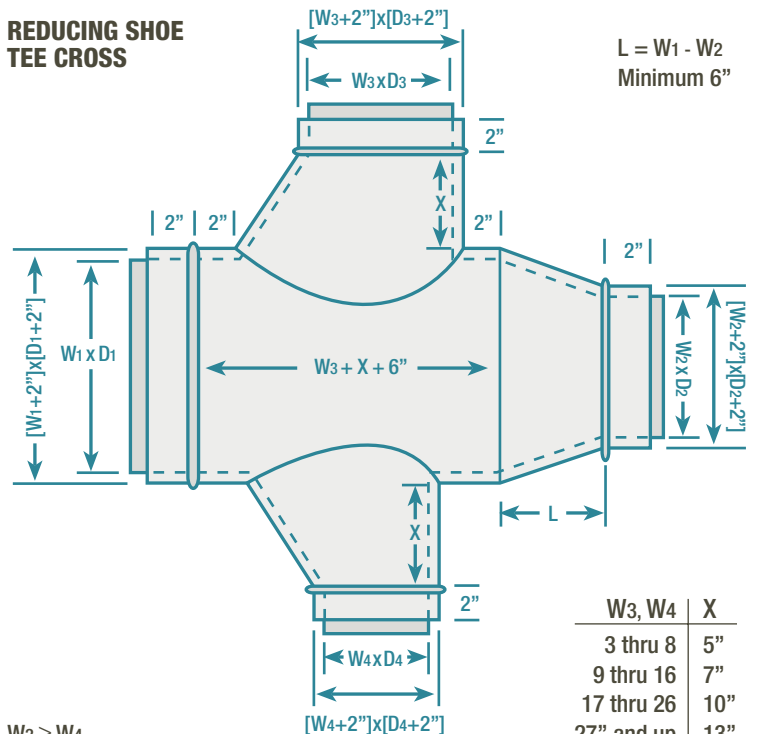

W ₃ , W ₄	X
3 thru 8	5"
9 thru 16	7"
17 thru 26	10"
27" and up	13"

Double Wall Oval STRAIGHT LATERALS

TAMBE METAL PRODUCTS

L

45° LATERAL

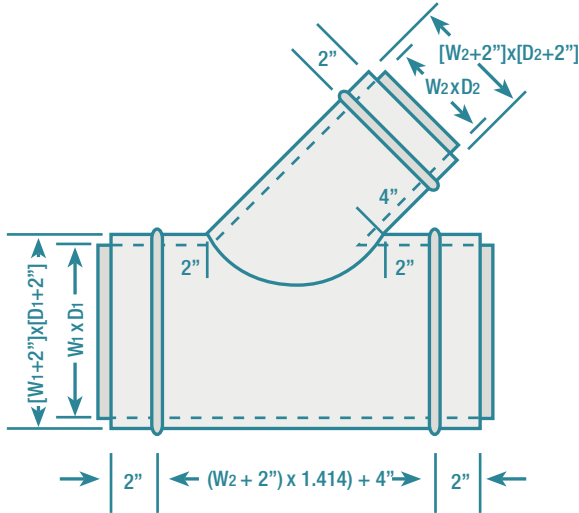

LR

45° REDUCING LATERAL

$L = W_1 - W_2$
6" Minimum

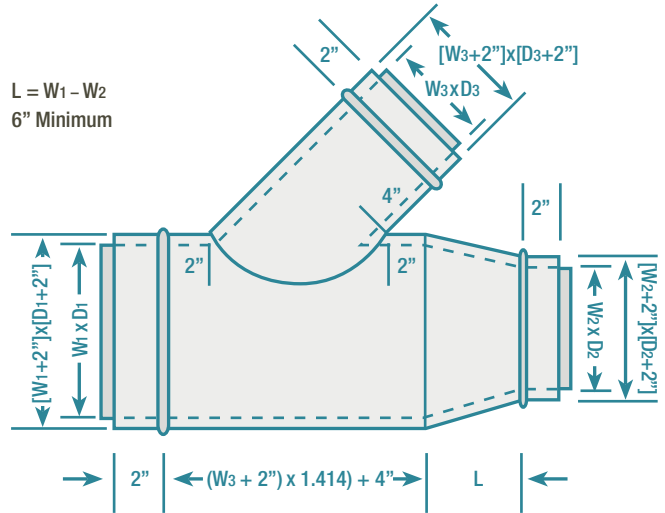

LX

45° LATERAL CROSS

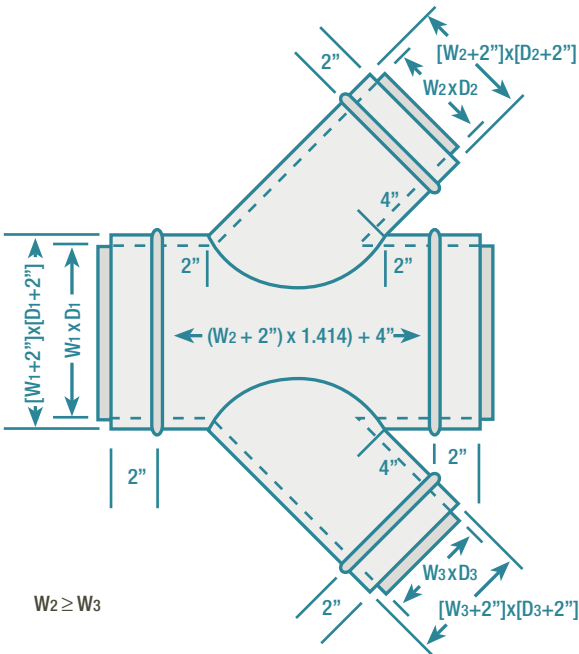

LRX

45° REDUCING LATERAL CROSS

$L = W_1 - W_2$
6" Minimum

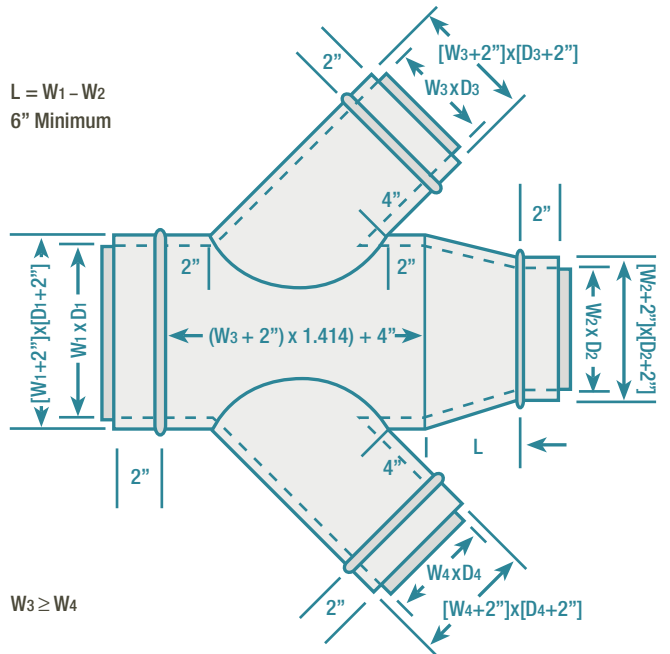

Double Wall Oval MISCELLANEOUS

TAMBE METAL PRODUCTS

RDC

CONCENTRIC REDUCER

$$L = W_1 - W_2$$

6" Minimum

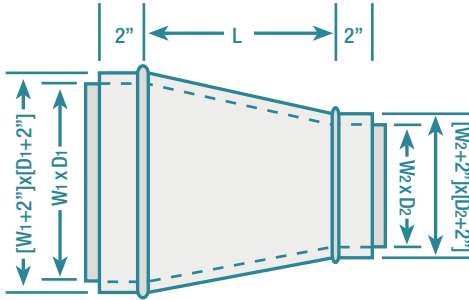

RDE

ECCENTRIC REDUCER

$$L = 2 [W_1 - W_2]$$

6" Minimum

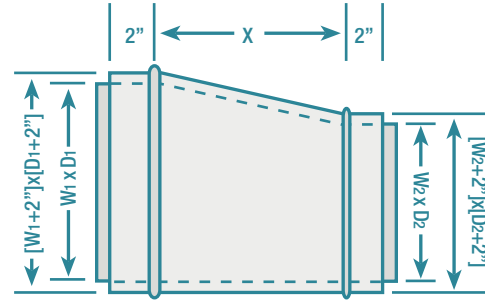

PC

PIPE COUPLING

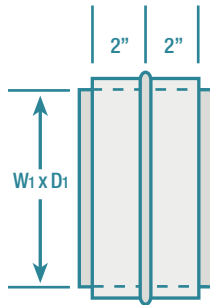

FC

FITTING COUPLING

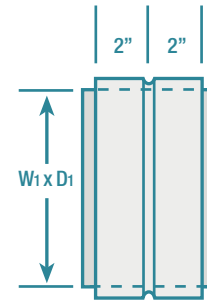

RTR

RECTANGULAR TO ROUND

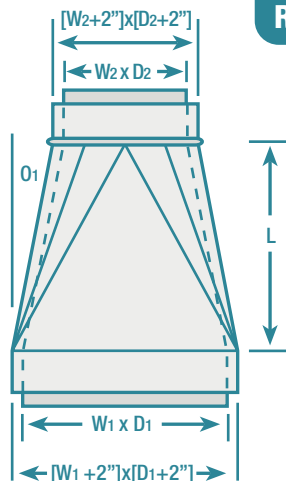

EC

END CAP

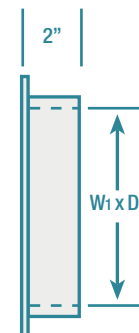

Double Wall Oval MISCELLANEOUS

TAMBE METAL PRODUCTS

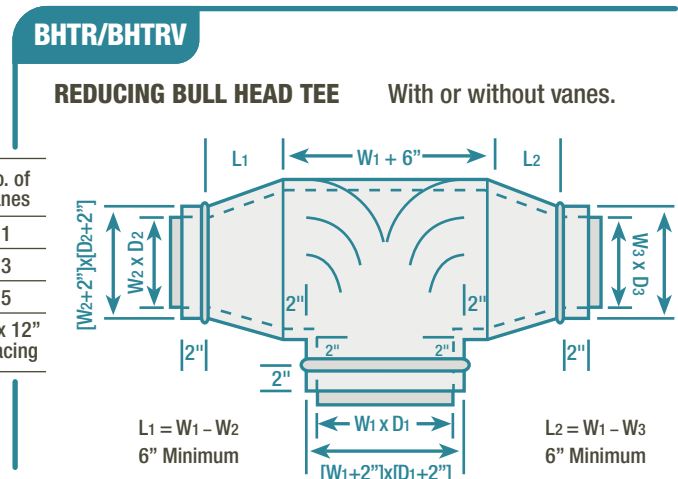
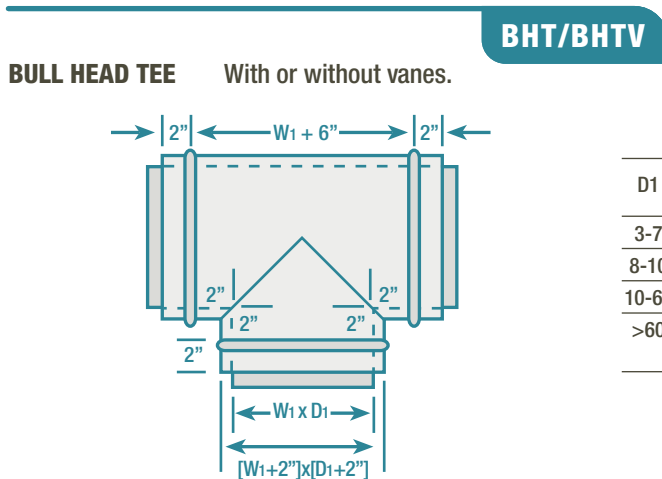
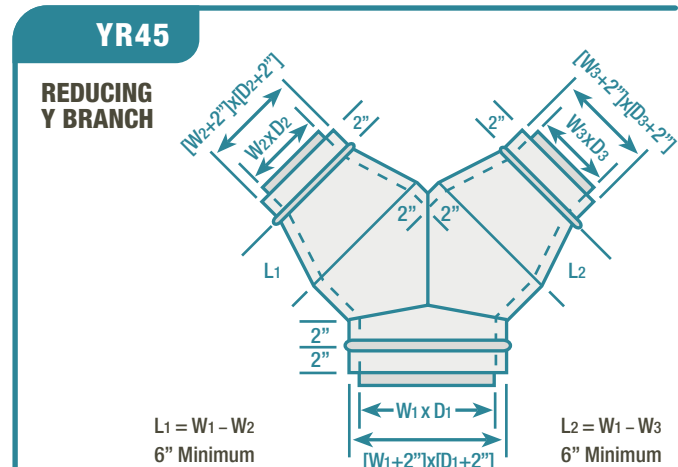
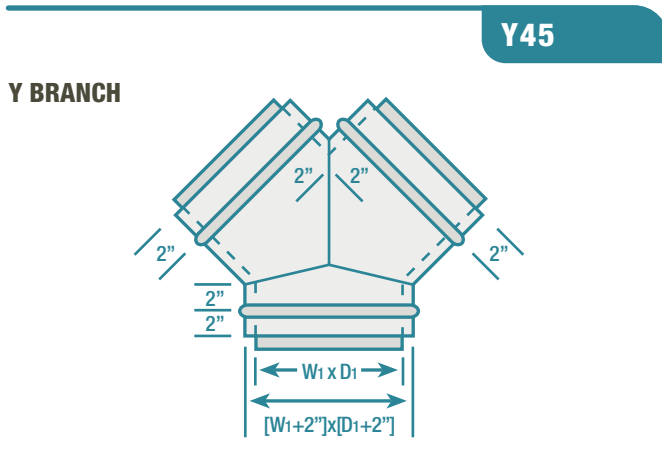
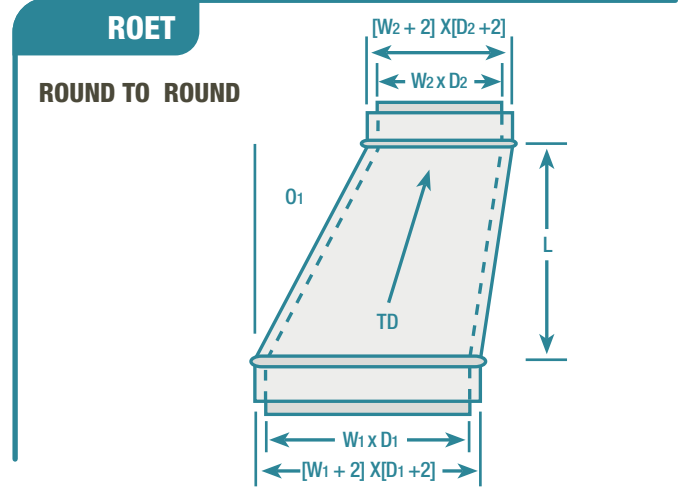
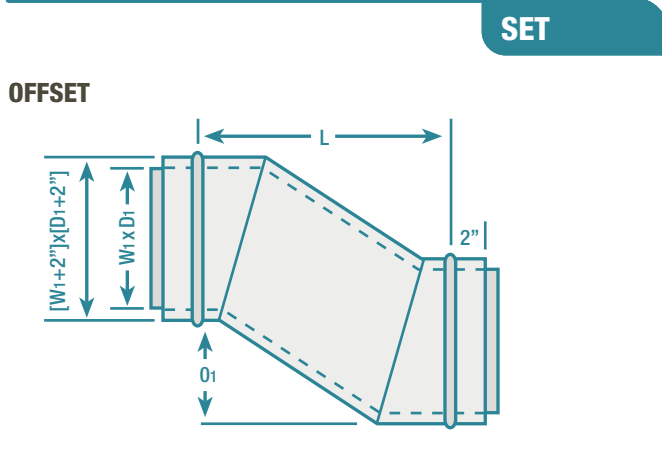

Shop/Field Installed **ACCESSORIES**

TAMBE METAL PRODUCTS

TAP 90

TAP

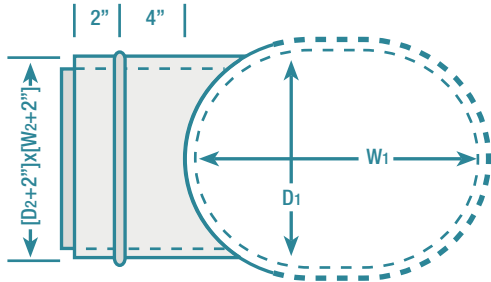

Standard flange is 1/2".
2" saddle is also available.

CTAP 90

CONICAL TAP

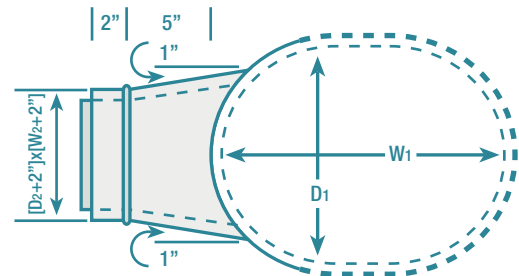

Standard flange is 1/2".
2" saddle is also available.

TAP 45

LATERAL TAP

Standard flange is 1/2". 2" saddle is also available.

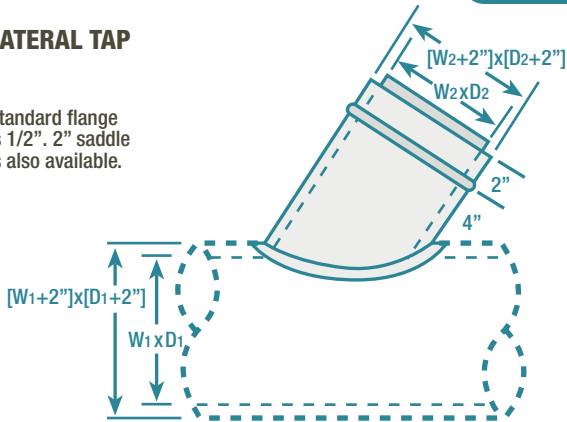

STR

SHOE TAP

W2	L
3 thru 8	5"
9 thru 16	7"
17 thru 26	10"
27" and up	13"

Standard flange is 1/2". 2" saddle is also available.

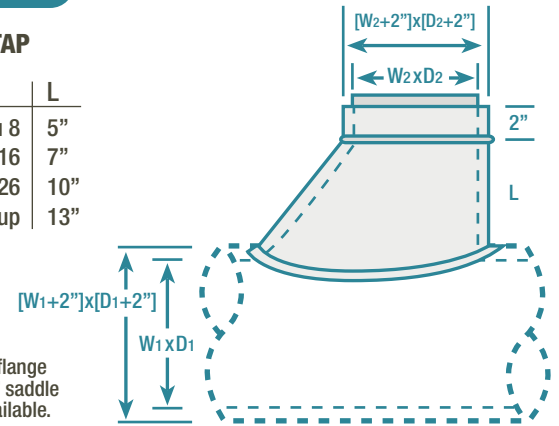

RECTAP

REGISTER TAP

Flange in or out

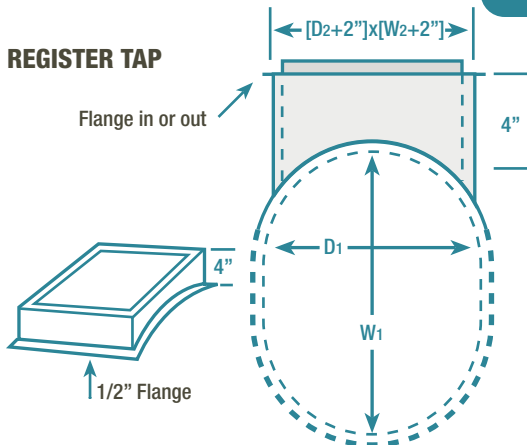

ADOOR

ACCESS DOOR

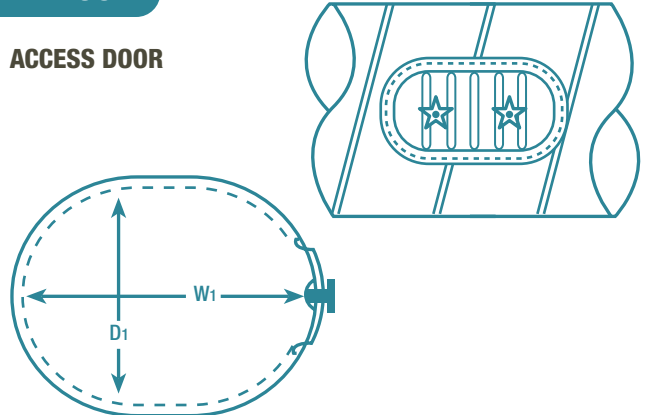

Rectangular Duct **SEAMS & CONNECTORS**

TAMBE METAL PRODUCTS

Connector Types



T- 1 Drive slip



T- 6 Hemmed "S" slip

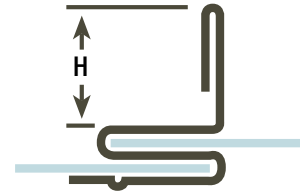

T-10 Standing S

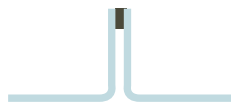

T- 21 Weld flange

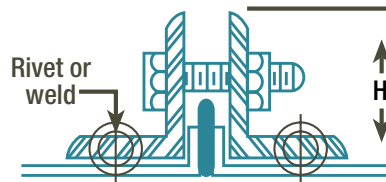

T- 22 Companion angles



Flanged
(With gasket)
T-25b

Seam Types



L-1 Pittsburgh lock



L-2 Button punch
snap lock

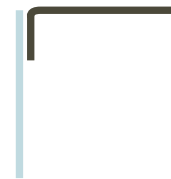

Lap seam



L-4 Standing seam



L-5 Single
corner seam



Corner weld

Rectangular Duct **STANDARDS**

TAMBE METAL PRODUCTS

TDF Connection

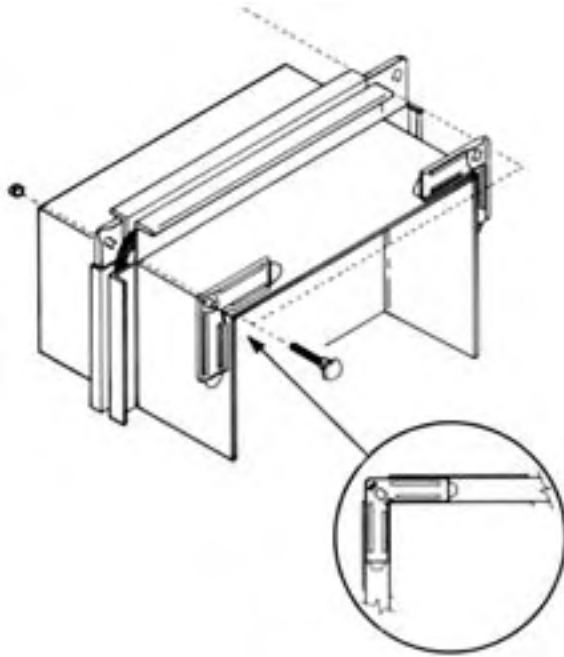

Recommended clip spacing

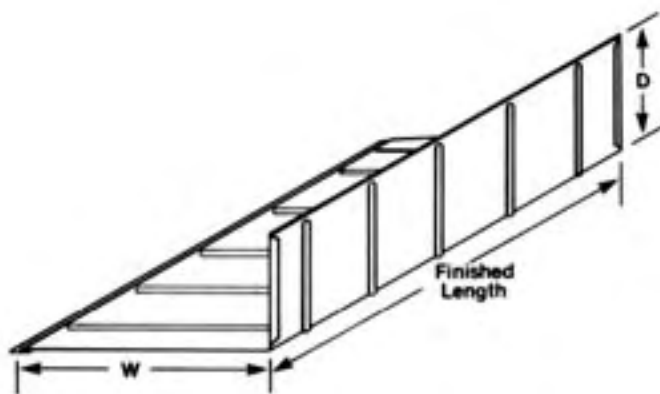
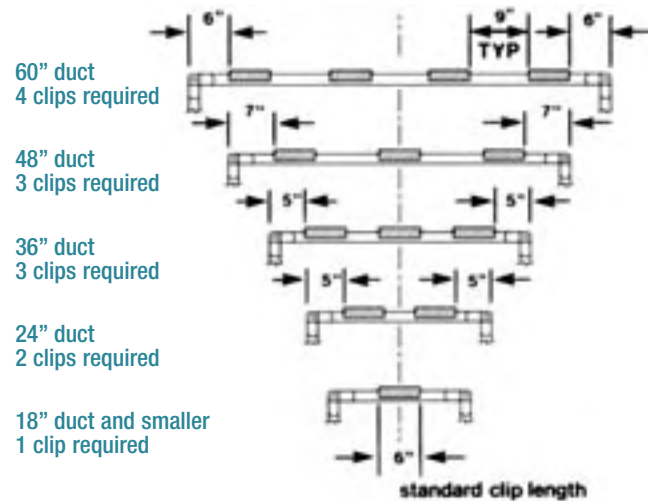

Straight Duct

Method of fabrication:

Two "L" shaped sections are assembled in the field to form the finished joint of ductwork. This allows ductwork to be shipped in knocked down condition requiring less cartage space and easier handling. Wrap around fabrication also available.

56" finished length with T.D.F.

59" finished length with drive cleat edges

60" length with ends unfinished

Weights on STRAIGHT and T.D.F.

TAMBE METAL PRODUCTS

DUCT SIZE TOTAL	Sq. Ft.	WEIGHT PER FOOT OF DUCT					DUCT SIZE TOTAL	Sq. Ft.	WEIGHT PER FOOT OF DUCT				
		26 gauge	24 gauge	22 gauge	20 gauge	18 gauge			26 gauge	24 gauge	22 gauge	20 gauge	18 gauge
12"	2.07	2.14	2.73	3.12	3.67	4.77	67"	11.49	10.70	13.64	16.60	19.55	25.45
13"	2.24	2.30	2.93	3.35	3.95	5.14	68"	11.66	10.85	13.84	16.84	19.83	25.82
14"	2.40	2.45	3.12	3.60	4.24	5.52	69"	11.84	11.00	14.04	17.08	20.12	26.20
15"	2.58	2.60	3.32	3.84	4.52	5.89	70"	12.02	11.16	14.25	17.33	20.41	26.58
16"	2.76	2.76	3.53	4.08	4.80	6.25	71"	12.19	11.31	14.44	17.56	20.69	26.95
17"	2.92	2.91	3.72	4.32	5.09	6.63	72"	12.36	11.47	14.64	17.80	20.98	27.32
18"	3.10	3.07	3.92	4.57	5.37	6.99	73"	12.53	11.62	14.84	18.04	21.26	27.68
19"	3.27	3.23	4.12	4.80	5.66	7.36	74"	12.70	11.78	15.04	18.29	21.55	28.05
20"	3.43	3.38	4.31	5.25	6.19	8.06	75"	12.87	11.94	15.24	18.54	21.83	28.42
21"	3.61	3.59	4.52	5.50	6.48	8.43	76"	13.05	12.10	15.44	18.79	22.12	28.80
22"	3.78	3.70	4.72	5.74	6.76	8.81	77"	13.22	12.25	15.63	19.02	22.40	29.16
23"	3.95	3.86	4.92	5.98	7.05	9.18	78"	13.39	12.41	15.83	19.26	22.68	29.53
24"	4.12	4.01	5.11	6.23	7.33	9.54	79"	13.56	12.56	16.03	19.49	22.96	29.90
25"	4.28	4.16	5.31	6.47	7.61	9.91	80"	13.73	12.72	16.23	19.73	23.25	30.27
26"	4.45	4.31	5.51	6.70	7.90	10.28	81"	13.90	12.88	16.42	19.98	23.53	30.64
27"	4.64	4.47	5.72	6.95	8.19	10.66	82"	14.08	13.04	16.62	20.23	23.82	31.02
28"	4.81	4.64	5.92	7.19	8.47	11.04	83"	14.25	13.19	16.82	20.47	24.10	31.38
29"	4.97	4.79	6.12	7.44	8.76	11.40	84"	14.42	13.35	17.03	20.71	24.39	31.75
30"	5.15	4.94	6.31	7.67	9.04	11.77	85"	14.59	13.50	17.22	20.95	24.67	32.13
31"	5.31	5.11	6.51	7.91	9.32	12.13	86"	14.76	13.65	17.42	21.19	24.96	32.49
32"	5.48	5.25	6.71	8.15	9.60	12.50	87"	14.93	13.81	17.62	21.43	25.24	32.87
33"	5.67	5.41	6.90	8.39	9.89	12.88	88"	15.11	13.97	17.83	21.68	25.53	33.25
34"	5.84	5.57	7.10	8.64	10.18	13.26	89"	15.28	14.12	18.02	21.92	25.81	33.61
35"	6.00	5.72	7.30	8.88	10.46	13.62	90"	15.45	14.28	18.22	22.16	26.10	33.98
36"	6.18	5.88	7.50	9.13	10.74	13.98	91"	15.62	14.43	18.41	22.40	26.38	34.34
37"	6.34	6.04	7.69	9.36	11.02	14.35	92"	15.79	14.58	18.61	22.64	26.66	34.71
38"	6.52	6.19	7.89	9.60	11.31	14.72	93"	15.96	14.74	18.81	22.88	26.95	35.08
39"	6.70	6.34	8.11	9.85	11.60	15.10	94"	16.14	14.90	19.01	23.12	27.24	35.46
40"	6.87	6.50	8.30	10.09	11.88	15.48	95"	16.31	15.05	19.21	23.36	27.52	35.82
41"	7.03	6.65	8.50	10.33	12.16	15.84	96"	16.48	15.21	19.41	23.61	27.80	36.19
42"	7.21	6.81	8.69	10.56	12.45	16.21	97"	16.65	15.36	19.60	23.84	28.08	36.56
43"	7.37	6.96	8.88	10.80	12.73	16.57	98"	16.82	15.52	19.80	24.08	28.37	36.93
44"	7.55	7.12	9.08	11.05	13.02	16.94	99"	16.99	15.67	20.00	24.33	28.65	37.31
45"	7.73	7.27	9.28	11.29	13.31	17.32	100"	17.17	15.83	20.21	24.58	28.94	37.69
46"	7.90	7.43	9.48	11.54	13.60	17.70	101"	17.34	15.98	20.40	24.81	29.22	38.05
47"	8.07	7.59	9.68	11.78	13.87	18.06	102"	17.51	16.14	20.60	25.05	29.51	38.42
48"	8.24	7.75	9.88	12.02	14.15	18.42	103"	17.68	16.29	20.79	25.29	29.79	38.78
49"	8.41	7.90	10.08	12.25	14.43	18.79	104"	17.85	16.45	20.99	25.53	30.08	39.15
50"	8.58	8.05	10.28	12.49	14.72	19.17	105"	18.02	16.61	21.19	25.78	30.36	39.52
51"	8.75	8.27	10.48	12.73	15.00	19.54	106"	18.20	16.77	21.39	26.03	30.65	39.90
52"	8.93	8.37	10.68	12.98	15.29	19.92	107"	18.37	16.92	21.58	26.26	30.93	40.26
53"	9.10	8.52	10.87	13.22	15.57	20.28	108"	18.54	17.07	21.78	26.50	31.21	40.63
54"	9.37	8.68	11.07	13.47	15.86	20.65	109"	18.71	17.23	21.98	26.74	31.49	41.00
55"	9.44	8.83	11.26	13.70	16.14	21.01	110"	18.88	17.39	22.18	26.98	31.78	41.38
56"	9.61	8.98	11.46	13.94	16.42	21.38	111"	19.05	17.55	22.38	27.22	32.06	41.75
57"	9.78	9.14	11.66	14.19	16.71	21.76	112"	19.23	17.71	22.59	27.47	32.35	42.13
58"	9.96	9.30	11.87	14.44	17.00	22.14	113"	19.40	17.86	22.78	27.71	32.63	42.49
59"	10.13	9.45	12.07	14.67	17.28	22.50	114"	19.57	18.01	22.98	27.95	32.92	42.86
60"	10.30	9.61	12.27	14.91	17.57	22.87	115"	19.74	18.16	23.17	28.19	33.20	43.22
61"	10.47	9.76	12.46	15.15	17.84	23.24	116"	19.91	18.31	23.37	28.43	33.48	43.59
62"	10.64	9.92	12.65	15.40	18.12	23.61	117"	20.08	18.47	23.57	28.67	33.77	43.97
63"	10.81	10.08	12.85	15.64	18.41	23.98	118"	20.26	18.63	23.78	28.92	34.06	44.35
64"	10.99	10.24	13.06	153.88	18.71	24.36	119"	20.44	18.79	23.98	29.16	34.35	44.72
65"	11.16	10.39	13.25	16.12	18.99	24.72	120"	20.66	18.95	24.18	29.40	34.63	45.09
66"	11.33	10.55	13.45	16.36	19.27	25.09							

Rectangular **ELBOWS**

TAMBE METAL PRODUCTS

RE/REV

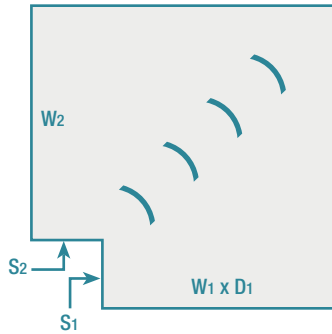

CER

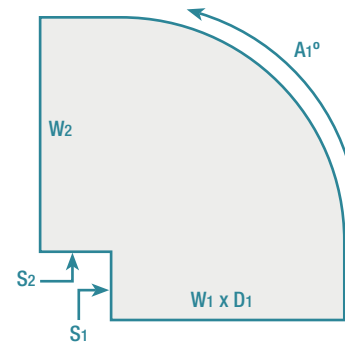

CET

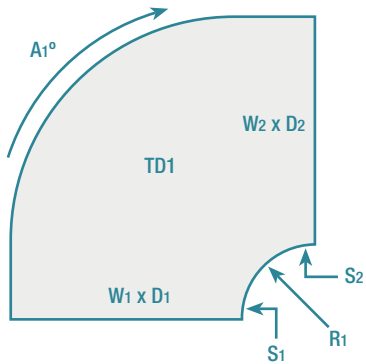

CETL

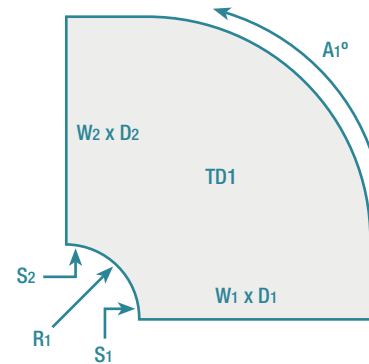

E

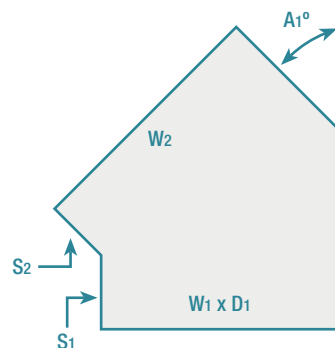

Rectangular TRANSITIONS

TAMBE METAL PRODUCTS

OG

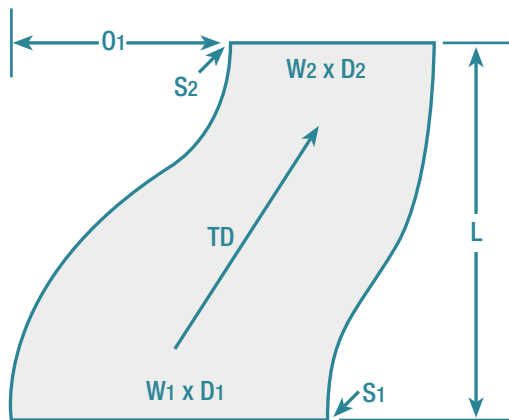

RDS2U

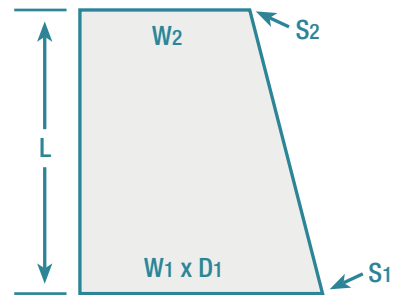

RS

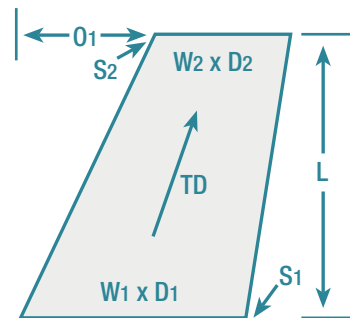

OGL

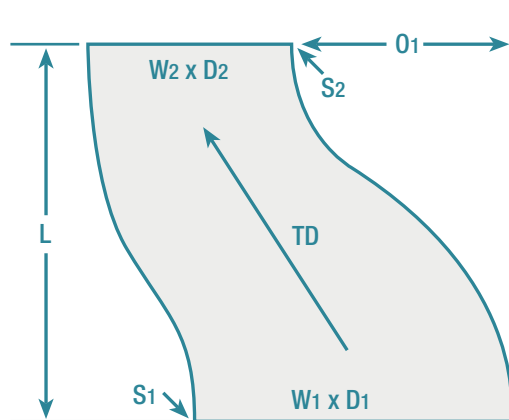

RSL

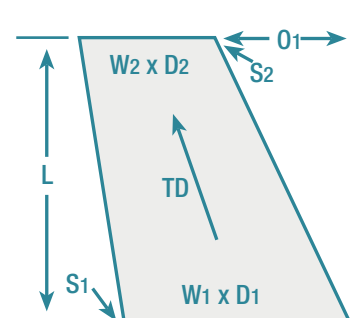

Rectangular Y'S & TEES

TAMBE METAL PRODUCTS

SCY

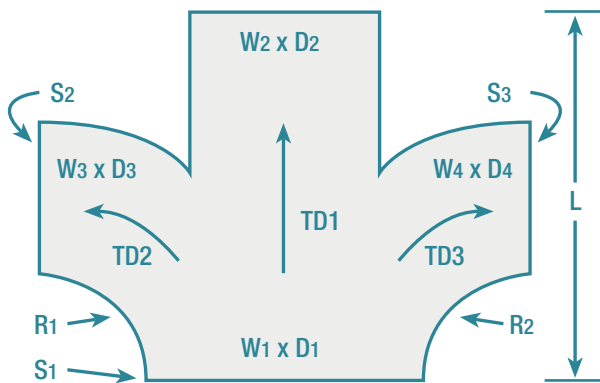

YS

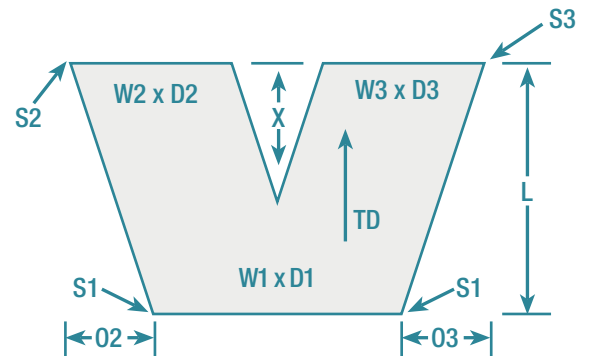

CYT

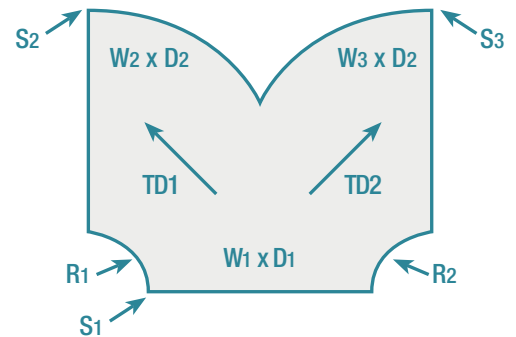

TEE/TEEV

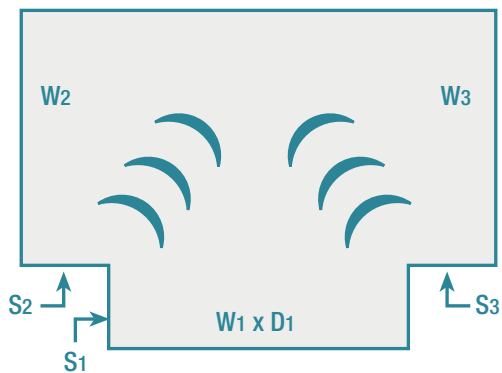

SCE

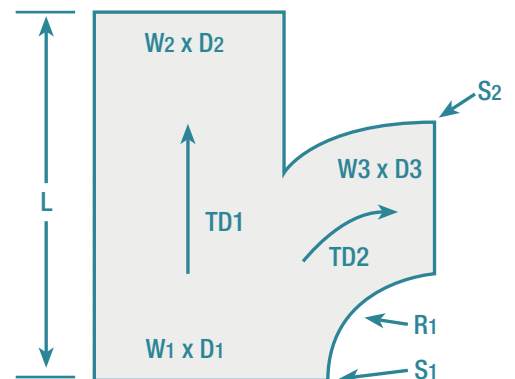

Rectangular MISCELLANEOUS

TAMBE METAL PRODUCTS

REO

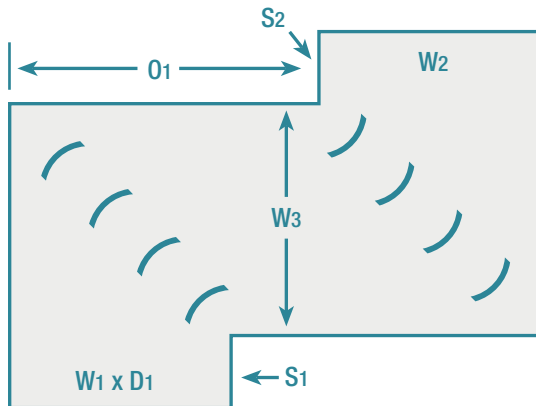

ATAP

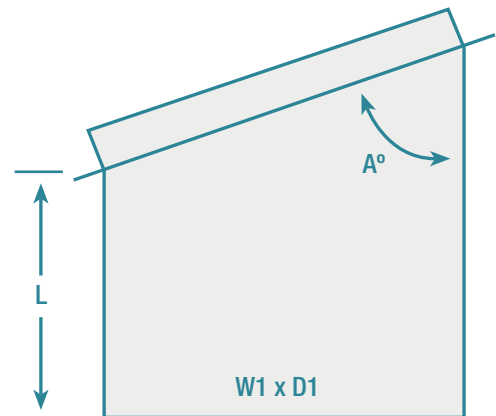

RO

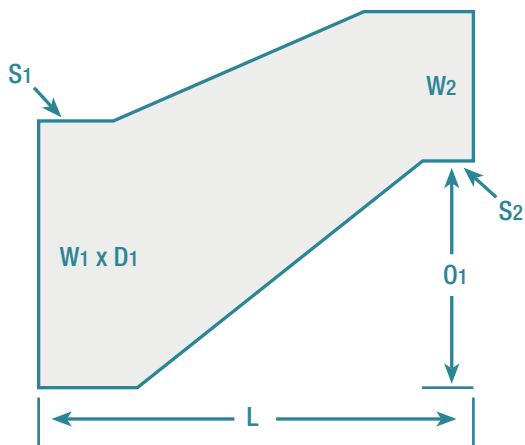

STAP

